

TOP END[®]

Terminator[™] Junior (JR)

DEALER: THIS MANUAL MUST BE GIVEN TO THE USER OF THE WHEELCHAIR.

USER: BEFORE USING THIS WHEELCHAIR, READ THIS MANUAL AND SAVE FOR FUTURE REFERENCE.



Yes, you can:

WARNING

DO NOT OPERATE THIS EQUIPMENT WITHOUT FIRST READING AND UNDERSTANDING THIS MANUAL. IF YOU ARE UNABLE TO UNDERSTAND THE WARNINGS, CAUTIONS AND INSTRUCTIONS, CONTACT A QUALIFIED TECHNICIAN OR TOP END CUSTOMER SUPPORT AT (800) 532-8677 BEFORE ATTEMPTING TO USE THIS EQUIPMENT - OTHERWISE INJURY AND/OR EQUIPMENT DAMAGE MAY RESULT.

SPECIAL NOTES

WARNING/CAUTION notices as used in this manual apply to hazards or unsafe practices which could result in personal injury or property damage.

NOTICE

THE INFORMATION CONTAINED IN THIS DOCUMENT IS SUBJECT TO CHANGE WITHOUT NOTICE.

As a manufacturer of wheelchairs, Invacare endeavors to supply a wide variety of wheelchairs to meet many needs of the end user. However, final selection of the type of wheelchair to be used by an individual rests solely with the user and his/her healthcare professional capable of making such a selection.

WHEELCHAIR TIE-DOWN RESTRAINTS AND SEAT POSITIONING STRAPS

Invacare recommends that wheelchair users NOT be transported in vehicles of any kind while in wheelchairs. As of this date, the Department of Transportation has not approved any tie-down systems for transportation of a user while in a wheelchair, in a moving vehicle of any type.

It is Invacare's position that users of wheelchairs should be transferred into appropriate seating in vehicles for transportation and use be made of the restraints made available by the auto industry. Invacare cannot and does not recommend any wheelchair transportation systems.

AS REGARDS RESTRAINTS - SEAT POSITIONING STRAPS - IT IS THE OBLIGATION OF THE DME DEALER, THERAPISTS AND OTHER HEALTHCARE PROFESSIONALS TO DETERMINE IF A SEATING POSITIONING STRAP IS REQUIRED TO ENSURE THE SAFE OPERATION OF THIS EQUIPMENT BY THE USER. SERIOUS INJURY CAN OCCUR IN THE EVENT OF A FALL FROM A WHEELCHAIR.

SAVE THESE INSTRUCTIONS

TABLE OF CONTENTS

WARNING/SPECIAL NOTES	2	PROCEDURE 6 - SEAT	23
SPECIFICATIONS	4	REPLACING SEAT PAN	23
PROCEDURE 1 - GENERAL GUIDELINES	5	ADJUSTING REAR SEAT HEIGHT	23
OPERATING INFORMATION	5	ADJUSTING SEAT DEPTH	23
SAFETY/HANDLING OF WHEELCHAIRS	6	ADJUSTING SEAT WIDTH	25
		ADJUSTING FRONT SEAT-TO-FLOOR HEIGHT	25
PROCEDURE 2 - SAFETY INSPECTION	10	PROCEDURE 7 - WHEELS	27
SAFETY INSPECTION CHECKLIST	10	REMOVING/INSTALLING REAR WHEELS	27
		ADJUSTING QUICK-RELEASE AXLES	27
PROCEDURE 3 - TROUBLESHOOTING/MAINTENANCE	11	INSTALLING QUAD-RELEASE AXLES	28
TROUBLESHOOTING	11	ADJUSTING QUAD-RELEASE HANDLES	28
MAINTENANCE	11	HANDRIM REPLACEMENT	28
		REPAIRING/REPLACING REAR WHEEL, TIRE/TUBE	29
PROCEDURE 4 - BACK	12	OPENING/CLOSING CLAMPS	29
FOLDING/UNFOLDING BACK	12	ADJUSTING REAR WHEEL CAMBER	30
CHANGING THE BACK ANGLE	12	DETERMINING/ADJUSTING TOE IN/TOE OUT	31
ADJUSTING THE BACK HEIGHT	13	ADJUSTING WHEELBASE LENGTH	32
REPLACING STANDARD BACK UPHOLSTERY ...	13	ADJUSTING WHEELBASE WIDTH	33
REPLACING CUSTOM MANUAL ADJUSTABLE TENSION BACK UPHOLSTERY	14	REPLACING AXLE TUBE	33
REPLACING THE SPREADER BAR	15	REPOSITIONING THE AXLE TUBE	34
REPLACING THE LOCKING MECHANISM IN THE BACK CANE	15	REPOSITIONING/REPLACING FRONT CASTERS	36
INSTALLING THE STROLLER HANDLES	16	ADJUSTING FRONT CASTER HEIGHT	36
		WHEEL LOCK ADJUSTMENT/REPLACEMENT ...	37
PROCEDURE 5 - ARMS	17	PROCEDURE 8 - FOOTREST/ANTI-TIPPER	38
USING CANTILEVER ARMS	17	ADJUSTING/REPLACING FLIP-UP FOOTBOARD	38
INSTALLING/REMOVING CANTILEVER ARMS	17	ADJUSTING/REPLACING RIGID TUBULAR FOOTREST	39
ADJUSTING CANTILEVER ARM HEIGHT	18	ANTI-TIPPER REPLACEMENT/ADJUSTMENT	39
ADJUSTING CANTILEVER ARM ANGLE	18		
REPLACING/REPOSITIONING THE CANTILEVER ARM LOCKING MECHANISM	19	PROCEDURE 9 - SUSPENSION	40
ARMREST PAD ADJUSTMENT/REPLACEMENT ...	19	ELASTOMERS AND SUSPENSION	40
INSTALLING T-ARM SOCKETS	20	REPLACING FRONT ELASTOMERS	40
INSTALLING/REMOVING T-ARMS	20		
ADJUSTING THE T-ARMS	20	LIMITED WARRANTY	43
REPLACING THE T-ARM LOCKING LEVER	22		

SPECIFICATIONS

**S
P
E
C
I
F
I
C
A
T
I
O
N
S**

NOTE: All specifications are approximate.

TERMINATOR JR.

Frame:	Rigid
Seat Width:	10-16-inch - Outside to Outside of SEAT FRAME in 1-inch increments.
Seat Depth	
Short Frame:	8 to 14-inches
Long Frame:	10 to 16-inches
Seat-to-Floor	
Front:	13 to 20-inches
Rear:	11 to 18-inches
Back Style:	Rigid (Standard), Fold Down
Back Height:	10 to 16-inches - Adjustable
Back Angle:	86°, 90°, 94°, 98°, 102° or 106°
Rear-Front Caster Distance (measured from outside of back of frame to center of front caster housing)	
Short Frame:	20.5-inches
Long Frame:	22.5-inches
Footrest:	Flip-up Footboard (standard), Tubular 4-inch Adjustable (optional)
Side - Wheel Clearance:	Adjustable 1/2 to 1-1/2-inches
Rear Axle:	Adjustable Axle Position, Telescoping
Rear Wheel Camber:	0°, 3°, 6°, 9° or 12° (Adjustable Camber System)
Rear Wheel Sizes:	18, 20, 22 or 24-inch
Available Tires	
18-inch:	18 x 1-3/8
20-inch:	20 x 1-3/8
22-inch:	22 x 1-3/8
24-inch:	24 x 1-3/8
Handrims:	Aluminum (standard) Plastic Coated (optional)
Wheel Locks:	High Mount Push to Lock
Front Forks:	Non-Shock Absorbing Fork (standard), Shock Absorbing (suspension) Fork (optional)
Caster Size:	3, 4 or 5-inch Solid, 5-inch Semi-Pneumatic (standard), 6-inch Pneumatic (optional)
Back Upholstery:	Non-adjustable (standard), U240 Black - Adjustable Tension
Weight:	30 lbs.
Shipping Weight*:	35 lbs.

**NOTE: 14 x 14-inch Seat Frame with complete package (22-inch wheels, folding back, push handles, solid seat pan, and anti-tippers).*

This Procedure includes the following:
Operating Information
Safety/Handling of Wheelchairs

STABILITY

STABILITY WARNING

The position of the footrest, camber tube, back angle, the tautness of the back upholstery as well as the user's condition are directly related to the wheelchairs stability. Any change to one (1) or any combination of the five (5) may cause the wheelchair to decrease in stability. Use EXTREME caution when using a new seating position.

	Footrest Position	Camber Tube	Back Angle	Back Upholstery	User Condition
Footrest Position	●		✓		✓
Camber Tube		●	✓		✓
Back Angle	✓		●	✓	✓
Back Upholstery			✓	●	✓
User Condition	✓	✓	✓	✓	●

NOTE: When changes to the left hand column occur, follow across the chart and refer to the ✓ procedure to maintain the proper stability, safety and handling of the racing chair.

OPERATING INFORMATION

WARNING

Unless otherwise noted, all service and adjustments should be performed while the wheelchair is unoccupied.

To determine and establish your particular safety limits, practice bending, reaching and transferring activities in several combinations in the presence of a qualified healthcare professional **BEFORE** attempting active use of the wheelchair.

DO NOT attempt to reach objects if you have to move forward in the seat.

DO NOT attempt to reach objects if you have to pick them up from the floor by reaching down between your knees.

DO NOT lean over the top of the back upholstery to reach objects behind you as this may cause the wheelchair to tip over.

DO NOT shift your weight or sitting position toward the direction you are reaching as the wheelchair may tip over.

DO NOT tilt the wheelchair without assistance.

DO NOT use an escalator to move a wheelchair between floors. Serious bodily injury may occur.

Before attempting to transfer in or out of the wheelchair, every precaution should be taken to reduce the gap distance. Turn both casters parallel to the object you are transferring onto. Also be certain the wheel locks are engaged to prevent the wheels from moving.

WARNING

DO NOT operate on roads, streets or highways.

DO NOT climb, go up or down ramps or traverse slopes greater than 9°.

DO NOT attempt to move up or down an incline with a water, ice or oil film.

DO NOT attempt to ride over curbs or obstacles. Doing so may cause your wheelchair to turn over and cause bodily harm or damage to the wheelchair.

DO NOT use ANY parts, accessories, or adapters other than those authorized by Invacare.

DO NOT attempt to lift the wheelchair by any removable (detachable) parts. Lifting by means of any removable (detachable) parts of a wheelchair may result in injury to the user or damage to the wheelchair.

DO NOT stand on the frame of the wheelchair.

OPTIONAL TUBULAR FOOTREST ONLY - Check ALL Allen screws securing the tubular footrest to the chair frame BEFORE using the wheelchair. ESPECIALLY if engaging in ANY rigorous activity.

Anti-tippers MUST BE attached at all times.

DO NOT use the footplate as a platform when getting in or out of the wheelchair.

ALWAYS wear your seat positioning strap. Inasmuch as the SEAT POSITIONING STRAP is an option on this wheelchair (You may order with or without the seat positioning strap), Invacare strongly recommends ordering the seat positioning strap as an additional safeguard for the wheelchair user.

TIRE PRESSURE

DO NOT use your wheelchair unless it has the proper tire pressure (p.s.i.). DO NOT overinflate the tires. Failure to follow these suggestions may cause the tire to explode and cause bodily harm. The recommended tire pressure is on the sidewall of the tire.

Replacement of the tire or tube MUST be performed by a qualified technician.

WEIGHT TRAINING

Invacare DOES NOT recommend the use of its wheelchairs as a weight training apparatus. Invacare wheelchairs have NOT been designed or tested as a seat for any kind of weight training. If occupant uses said wheelchair as a weight training apparatus, Invacare shall NOT be liable for bodily injury and the warranty is void.

WEIGHT LIMITATION

Invacare's Top End Terminator JR wheelchair has a weight limitation of 150 lbs.

SAFETY/HANDLING OF WHEELCHAIRS

“Safety and Handling” of the wheelchair requires the close attention of the wheelchair user as well as the assistant. This manual points out the most common procedures and techniques involved in the safe operation and maintenance of the wheelchair. It is important to practice and master these safe techniques until you are comfortable in maneuvering around the frequently encountered architectural barriers.

Use this information only as a “basic” guide. The techniques that are discussed on the following pages have been used successfully by many.

Individual wheelchair users often develop skills to deal with daily living activities that may differ from those described in this manual. Invacare recognizes and encourages each individual to try what works best for him/her in overcoming architectural obstacles that they may encounter, however, ALL WARNINGS and CAUTIONS given in this manual MUST be followed. Techniques in this manual are a starting point for the new wheelchair user and assistant with “safety” as the most important consideration for all.

Stability and Balance

WARNING

ALWAYS wear your seat positioning strap. Inasmuch as the SEAT POSITIONING STRAP is an option on this wheelchair (You may order with or without the seat positioning strap), Invacare strongly recommends ordering the seat positioning strap as an additional safeguard for the wheelchair user.

Anti-tippers MUST BE attached at all times.

To assure stability and proper operation of your wheelchair, you must at all times maintain proper balance. Your wheelchair has been designed to remain upright and stable during normal daily activities as long as you do not move beyond the center of gravity.

Virtually all activities which involve movement in the wheelchair have an effect on the center of gravity. Invacare recommends using seat positioning straps for additional safety while involved in activities that shift your weight.

DO NOT lean forward out of the wheelchair any further than stability will allow. Make sure casters are pointing in the forward position whenever you lean forward. This can be achieved by advancing the wheelchair and then reversing it in a straight line.

Coping with Everyday Obstacles

Coping with the irritation of everyday obstacles can be alleviated somewhat by learning how to manage your wheelchair. Keep in mind your center of gravity to maintain stability and balance.

A Note to Wheelchair Assistants

When assistance to the wheelchair user is required, remember to use good body mechanics. Keep your back straight and bend your knees whenever tilting the wheelchair or traversing curbs, or other impediments.

WARNING

Do not attempt to lift a wheelchair by lifting on any removable (detachable) parts. Lifting by means of any removable (detachable) parts of a wheelchair may result in injury to the user or damage to the wheelchair.

Also, be aware of any removable (detachable) parts. These must NEVER be used for hand-hold or lifting supports, as they may be inadvertently released, resulting in possible injury to the user and/or assistant(s).

When learning a new assistance technique, have an experienced assistant help you before attempting it alone.

Percentage of Weight Distribution

WARNING

DO NOT attempt to reach objects if you have to move forward in the seat or pick them up from the floor by reaching down between your knees.

The position of the footrest, camber tube, back angle, the tautness of the back upholstery as well as the user's condition are directly related to the wheelchairs stability. Any change to one (1) or any combination of the five (5) may cause the wheelchair to decrease in stability. Use EXTREME caution when using a new seating position.

Many activities require the wheelchair owner to reach, bend and transfer in and out of the wheelchair. These movements will cause a change to the normal balance, the center of gravity, and the weight distribution of the wheelchair. To determine and establish your particular safety limits, practice bending, reaching and transferring activities in several combinations in the presence of a qualified health-care professional BEFORE attempting active use of wheelchair.

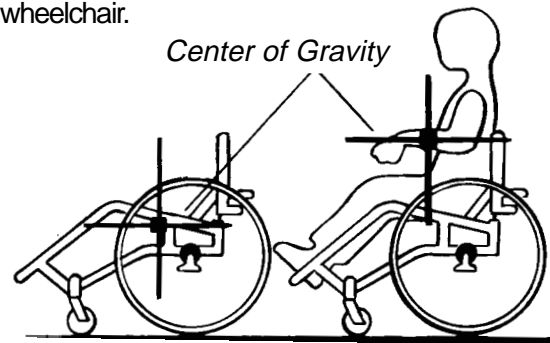

Example: 46% 54% 103 lbs. 130 lbs.

UNOCCUPIED

OCCUPIED

Proper positioning is essential for your safety. When reaching, leaning, bending forward, it is important to use the front casters as a tool to maintain stability and balance.

LENGTHENING THE WHEELBASE will increase the stability and maintain standard maneuverability of wheelchair.

SHORTENING THE WHEELBASE will increase the maneuverability, distribute additional weight onto the rear wheels, and decrease the stability of the wheelchair.

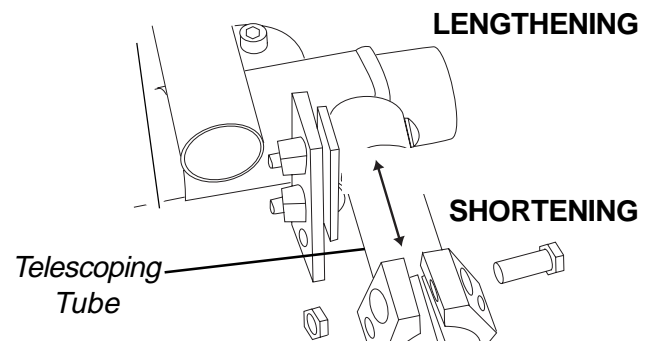

GENERAL GUIDELINES

Functional Reach From a Wheelchair

The approximate reach-limit values shown in the accompanying graphs were derived on the basis of a sample of 91 male and 36 female wheelchair users. Note the difference between the maximum and the comfortable reach limits, a subjective but important consideration in design.

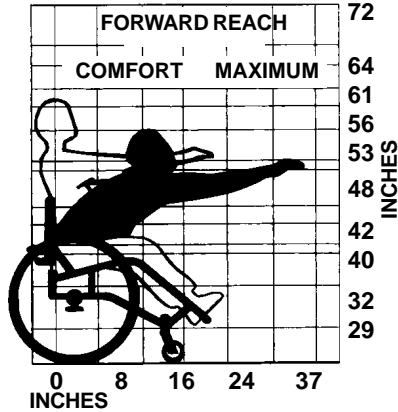

Reaching, Leaning and Bending Forward

Position the front casters so that they are extended as far forward as possible and engage wheel locks.

WARNING
DO NOT attempt to reach objects if you have to move forward in the seat or pick them up from the floor by reaching down between your knees.

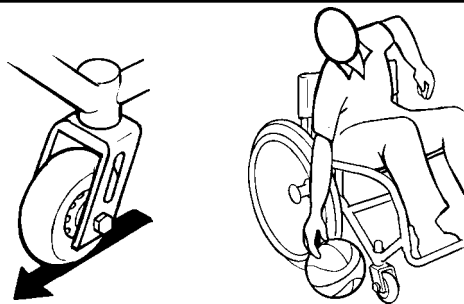

REACHING, LEANING AND BENDING - FORWARD

Reaching, Leaning - Backwards

WARNING
DO NOT lean over the top of the back upholstery. This will change your center of gravity and may cause you to tip over.



REACHING, LEANING - BACKWARDS

Tilting

WARNING
DO NOT tilt the wheelchair without assistance.
When lowering the front casters of the wheelchair, DO NOT let the wheelchair drop the last few inches to the ground. This could result in injury to the occupant and/or damage to the wheelchair.

When tilting the wheelchair, an assistant should grasp the back of the wheelchair on a non-removable (non-detachable) part. Inform the wheelchair occupant before tilting the wheelchair and remind him/her to lean back. Be sure the occupant's feet and hands are clear of all wheels.

TILTING - CURBS:

After mastering the techniques of tilting the wheelchair, use this procedure to tackle curbs, short stairs, etc.

METHOD 1 - Apply a continuous downward motion until the balance point is achieved and the front casters clear the curb. At this point, the assistant will feel a difference in the weight distribution.

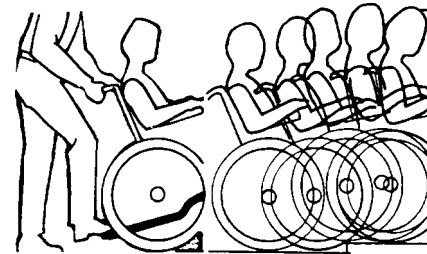

METHOD 1

Roll the wheelchair forward and slowly lower the front casters onto the sidewalk. Do not let the wheelchair drop the last few inches to the ground. This could result in injury to the occupant. Push the wheelchair forward until the rear wheels roll up and over the curb.

METHOD 2 - This method requires two (2) assistants. The second assistant should be positioned at the front of the wheelchair lifting upward on a non-removable (non-detachable) part of the wheelchair frame when lifting the wheelchair and stabilizing the wheelchair when the wheelchair is being lowered to the ground.

The first assistant should stand on the sidewalk and turn the wheelchair so that the rear wheels are against the curb. The wheelchair should be tilted back to the balance point and, in one continuous upward movement, the rear wheels should be pulled up and over the curb. DO NOT return the front casters to the ground until the wheelchair has been pulled backward far enough for the front casters to clear the edge of the curb.

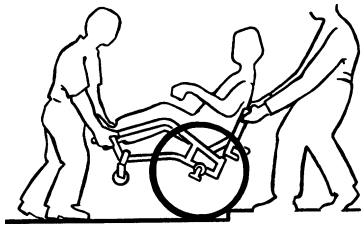

METHOD 2

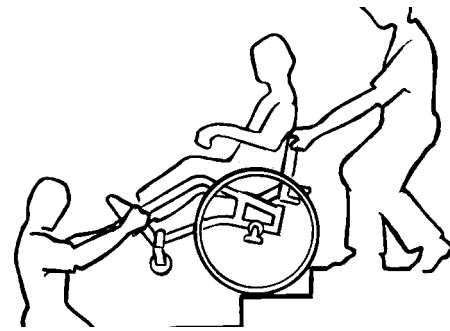

Stairways

WARNING

ALWAYS wear your seat positioning strap. Inasmuch as the SEAT POSITIONING STRAP is an option on this wheelchair (You may order with or without the seat positioning strap), Invacare strongly recommends ordering the seat positioning strap as an additional safeguard for the wheelchair user.

DO NOT attempt to lift the wheelchair by any removable (detachable) parts. Lifting by means of any removable (detachable) parts of a wheelchair may result in injury to the user or damage to the wheelchair.

Extreme caution is advised when it is necessary to move an occupied wheelchair up or down a stairway. Invacare recommends using two (2) assistants and making thorough preparations. Make sure to use ONLY secure, non-detachable parts for hand-hold supports.

Follow this procedure for moving the wheelchair between floors when an elevator is NOT available:

1. Turn the anti-tippers so they are facing UP.
2. After the wheelchair has been tilted back to the balance point, one assistant (in the rear) backs the wheelchair up against the first step, while securely grasping a non-removable (non-detachable) part of the wheelchair for leverage.
3. The second assistant, with a firm hold on a non-detachable part of the framework, lifts the wheelchair up and over the stair and steadies it as the first assistant places one foot on the next stair and repeats procedure.
4. The wheelchair should not be lowered until the last stair has been negotiated and it has been rolled away from the stairway.
5. Turn the anti-tippers so they are facing DOWN.

ESCALATORS? SORRY!

DO NOT use an escalator to move a wheelchair between floors. Serious bodily injury may occur.

Transferring to and From Other Seats

WARNING

BEFORE attempting to transfer in or out of the wheelchair, every precaution should be taken to reduce the gap distance. Turn both casters parallel to the object you are transferring onto. Also be certain the wheel locks are engaged to help prevent the wheels from moving.

CAUTION

When transferring, position yourself as far back as possible in the seat. This will prevent damaged upholstery and the possibility of the wheelchair tipping forward.

NOTE: This activity may be performed independently provided you have adequate mobility and upper body strength.

Position the wheelchair as close as possible along side the seat to which you are transferring, with the front casters pointing parallel to it. Engage wheel locks. Shift body weight into seat with transfer.

During independent transfer, little or no seat platform will be beneath you. Use a transfer board if at all possible.



This Procedure includes the following:
Safety Inspection Checklist

S
A
F
E
T
Y
I
N
S
P
E
C
T
I
O
N

SAFETY INSPECTION CHECKLIST

NOTE: Every six (6) months, take your wheelchair to a qualified technician for a thorough inspection and servicing. Regular cleaning will reveal loose or worn parts and enhance the smooth operation of your wheelchair. To operate properly and safely, your wheelchair must be cared for just like any other vehicle. Routine maintenance will extend the life and efficiency of your wheelchair. Clean upholstery with mild soap and water or spray disinfectant using a sponge. DO NOT use bleach or wash in a washing machine.

Initial adjustments should be made to suit your personal body structure, preference and abilities. Thereafter follow these maintenance procedures:

ITEM	INITIALLY	INSPECT/ ADJUST WEEKLY	INSPECT/ ADJUST MONTHLY	INSPECT/ ADJUST PERIODICALLY
GENERAL Wheelchair rolls straight (no excessive drag or pull to one side).	X			X
WHEEL LOCKS Do not interfere with tires when rolling. Pivot points free of wear and looseness. Wheel locks easy to engage.	X X X		X X	X
SEAT AND BACK UPHOLSTERY Inspect for rips or sagging. Inspect fastening flaps to ensure they securely latch.	X X		X	X
REAR WHEELS Adjustable Axle Position Camber Bar is securely tightened. Quick/Quad release axles lock properly. No excessive side movement or binding when lifted and spun.	X X X	X	X	X X
HANDRIMS Inspect for signs of rough edges or peeling.	X			X
SPOKES Inspect for bent or broken spokes. All spokes uniformly tight.	X X	X X		
FRONT CASTER Inspect wheel/fork assembly for proper tension by spinning caster; caster should come to a gradual stop. Loosen/tighten locknut if wheel wobbles noticeably or binds to a stop. Wheel bearings are clean and free of moisture. CAUTION: As with any vehicle, the wheels and tires should be checked periodically for cracks and wear, and should be replaced.	X X X	X	X X	X
TIRES Inspect for flat spots and wear. If pneumatic tires check for proper inflation. CAUTION: As with any vehicle, the wheels and tires should be checked periodically for cracks and wear, and should be replaced.	X X	X X		
FRONT SUSPENSION FORKS (If Equipped) Inspect elastomers for proper lubrication.				X
CLEANING Clean upholstery and armrests.	X			X

This Procedure includes the following:
Troubleshooting
Maintenance

TROUBLESHOOTING

CHAIR VEERS RIGHT	CHAIR VEERS LEFT	SLUGGISH TURN OR PERFORMANCE	CASTER FLUTTERS	SQUEAKS AND RATTLES	LOOSENESS IN CHAIR	SOLUTIONS
X	X	X	X			Check tires for correct and equal pressure.
		X	X	X	X	Check for loose stem nuts.
				X	X	Check spokes and nipples.
X	X		X			Check that both casters contact the ground at the same time.

TROUBLESHOOTING

MAINTENANCE

Maintenance Safety Precautions

WARNING

After ANY adjustments, repair or service and BEFORE use, make sure all attaching hardware is tightened securely - otherwise injury or damage may result.

CAUTION

DO NOT overtighten hardware attaching to the frame. This could cause damage to the frame tubing.

- Recommended tire pressure is listed on the sidewall of the tire.

CAUTION

As with any vehicle, the wheels and tires should be checked periodically for cracks and wear, and should be replaced.

Suggested Maintenance Procedures

- Before using your wheelchair, make sure all nuts and bolts are tight. Check all parts for damage or wear and replace. Check all parts for proper adjustment.
- Keep quick/quad-release axles free of dirt and lint to ensure positive locking and proper operation. Refer to ADJUSTING QUICK-RELEASE AXLES or ADJUSTING QUAD-RELEASE HANDLES in PROCEDURE 7 of this manual.
- Oil quick-release axles at least once (1) a month (3-in-1 oil® or equivalent).

WARNING

DO NOT use your wheelchair unless it has the proper tire pressure (p.s.i.). DO NOT overinflate the tires. Failure to follow these suggestions may cause the tire to explode and cause bodily harm.

- Check the wheels and tires periodically for cracks and wear. If damaged, have them replaced by a qualified technician.
- Regularly check for loose spokes in the rear wheels. If loose, have them adjusted by a qualified technician.
- Periodically check handrims to ensure they are secured to the rear wheels. Refer to HANDRIM REPLACEMENT in PROCEDURE 7 of this manual.
- Periodically adjust wheel locks in correlation to tire wear. Refer to WHEEL LOCK ADJUSTMENT/REPLACEMENT in PROCEDURE 7 of this manual.
- Periodically check caster wheel bearings to make sure they are clean and free from moisture. Use a Teflon® lubricant if necessary.
- FRONT SUSPENSION FORKS (if equipped)** - Periodically lubricate the the inside of the elastomers and the shaft of the hex bolt that secures the elastomers to the suspension tube with a silicone based lubricant.
- Check upholstery for sagging, rips or tears.

MAINTENANCE

This Procedure includes the following:

- Folding/Unfolding the Back*
- Changing the Back Angle*
- Adjusting the Back Height*
- Replacing Standard Back Upholstery*
- Replacing Custom Manual Adjustable Tension Back Upholstery*
- Replacing the Spreader Bar*
- Replacing the Locking Mechanism in the Back Cane*
- Installing the Stroller Handles*

WARNING

ALWAYS perform this procedure in the presence of an assistant. The position of the footrest, camber tube, back angle, the tautness of the back upholstery as well as the user's condition are directly related to the wheelchairs stability. Any change to one (1) or any combination of the five (5) may cause the wheelchair to decrease in stability. Use EXTREME caution when using a new seating position.

After ANY adjustments, repair or service and BEFORE use, make sure all attaching hardware is tightened securely - otherwise injury or damage may result.

FOLDING/UNFOLDING THE BACK (FIGURE 1)

WARNING

Back MUST be locked securely in place and all attaching hardware tight BEFORE using the wheelchair.

Folding the Back

1. Pull BOTH back release levers UP.
2. While holding BOTH back release levers, push the back canes DOWN.

Unfolding the Back

1. Pull the back canes UP towards the rear of the wheelchair there is an audible "click".
2. Push the back canes FORWARD to ensure they are locked in place.
3. If the back canes are not locked in place, repeat STEPS 1-2 until the back canes lock.

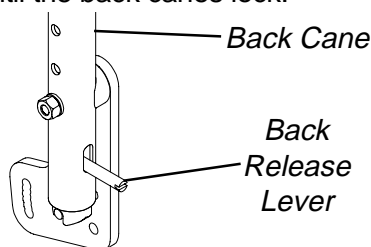

FIGURE 1 - FOLDING/UNFOLDING THE BACK

CHANGING THE BACK ANGLE (FIGURE 2)

WARNING

The following procedure MUST be performed by a qualified technician.

1. Remove the seat pan. Refer to REPLACING SEAT PAN in PROCEDURE 6 of this manual.
2. Loosen, but do not remove the rear hex screw that secures the back angle plate to the wheelchair frame.
3. Remove the front hex screw, washers, coved washer and locknut that secure the back angle plate to the wheelchair frame.
4. Position the back angle plate to one (1) of six (6) back angles shown in FIGURE 2.
5. Reinstall the front hex screw, washers and coved washer and securely tighten with locknut. Refer to FIGURE 2 for correct hardware orientation.
6. Securely tighten the rear hex screw that secures the back adjustment plate to the wheelchair frame.
7. If wheelchair is equipped with cantilever arms, adjust the angle of the cantilever arm so they remain parallel to the ground/floor. Refer to ADJUSTING CANTILEVER ARM ANGLE in PROCEDURE 5 of this manual.

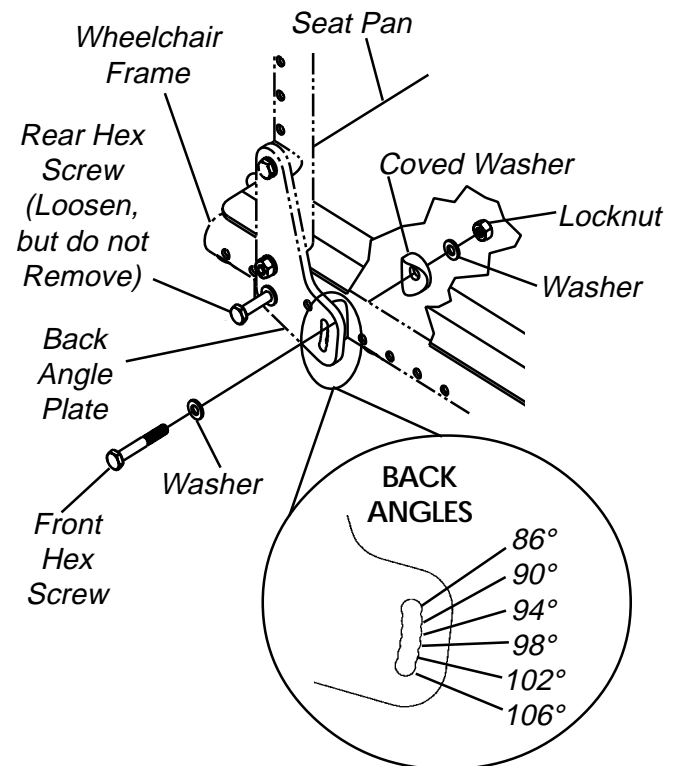

FIGURE 2 - CHANGING THE BACK ANGLE

**ADJUSTING THE BACK HEIGHT
(FIGURE 3)**

NOTE: If necessary, remove the back upholstery to access mounting holes. Refer to REPLACING STANDARD BACK UPHOLSTERY or REPLACING CUSTOM MANUAL ADJUSTABLE TENSION BACK UPHOLSTERY in this procedure of the manual.

1. Remove the back height adjustment screws that secure the back cane to the back upright.
2. Raise/lower the back canes to the desired height.
3. Align the mounting hole in each back cane with the desired mounting hole in each back upright.

NOTE: Both back canes should be adjusted to the same height.

4. Install the two (2) back height adjustment screws through the back upright mounting holes determined in STEP 3 and the back cane mounting holes.

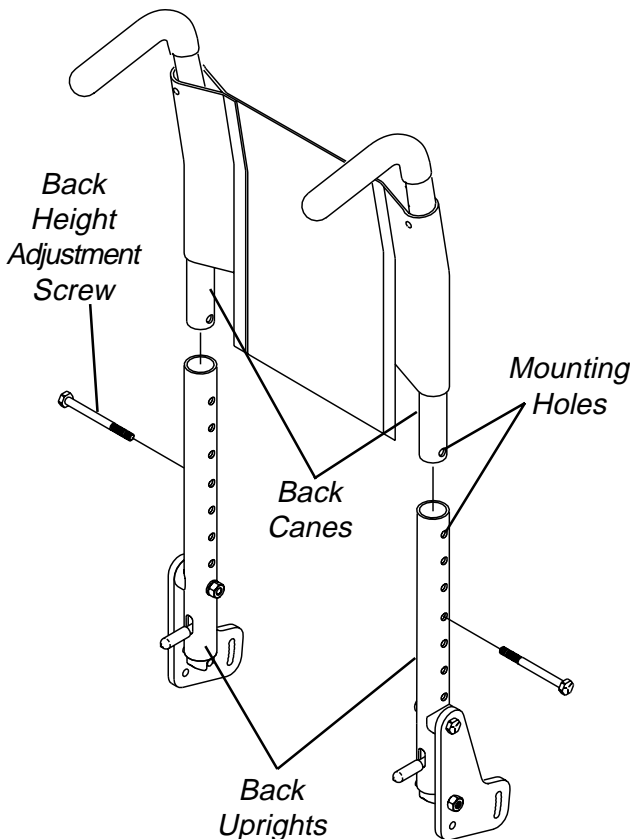

NOTE: Standard back upholstery shown for clarity.

FIGURE 3 - ADJUSTING THE BACK HEIGHT

**REPLACING STANDARD BACK UPHOLSTERY
(FIGURE 4)**

1. Remove the back height adjustment screws that secure the back cane to the back upright.
2. Slide the back assembly out of the back uprights.
3. Remove the two (2) screws and washers that secure the EXISTING back upholstery to the back cane.
4. Slide the EXISTING back upholstery down and off the back canes.
5. Slide the NEW back upholstery up and onto the back canes.
6. Align the mounting hole in each back cane with the desired mounting hole in each back upright.

NOTE: Both back canes should be adjusted to the same height.

7. Install the two (2) back height adjustment screws through the back upright mounting holes determined in STEP 6 and the back cane mounting holes.

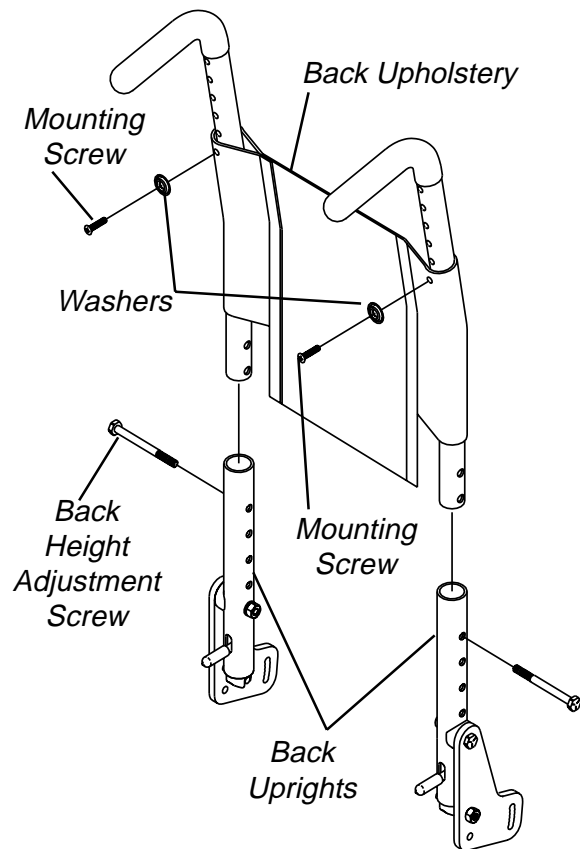

FIGURE 4 - REPLACING STANDARD BACK UPHOLSTERY

**B
A
C
K**

BACK

REPLACING CUSTOM MANUAL ADJUSTABLE TENSION BACK UPHOLSTERY (FIGURE 5)

The Adjustable Tension Straps

The straps can be adjusted at various levels of tension to accommodate individual end-users. The bottom two (2) straps can be adjusted tightly to support and/or assist the extensor muscles.

The Back Upholstery Cover

The back upholstery cover is designed for three (3) reasons:

1. The first is as a modesty cover.
2. The second is to keep the cushion from sliding out of the back of the wheelchair.
3. The third is a sacral support depending upon how far or tight the flap is pulled under the seat cushion.

Replacing Adjustable Tension Back Upholstery

1. Remove the back height adjustment screws that secure the back canes to the back uprights.
2. Slide the back canes out of the back uprights.
3. Remove the two (2) screws and washers that secure the EXISTING back upholstery to the back canes.
4. Slide the EXISTING back upholstery down and off the back canes.
5. Stand behind the wheelchair and perform the following:
 - A. Slide anchor loop section of adjustable tension back upholstery up onto the LEFT back cane with the upper grommet hole facing the rear of the wheelchair.
 - B. Slide adjuster strap section of adjustable tension back upholstery up onto the RIGHT back cane with the upper grommet hole facing the rear of the wheelchair.
6. Align the mounting hole in each back cane with the desired mounting hole in each back upright.

NOTE: Both back canes should be adjusted to the same height.

7. Install the two (2) back height adjustment screws through the back upright mounting holes determined in STEP 6 and the back cane mounting holes.
8. Slip adjuster straps through corresponding anchor loops and adjust the back upholstery. Secure with the fastening straps.

WARNING

After the adjustable tension back upholstery has been positioned to the end-user's individual needs, the fastening straps **MUST** be securely fastened **BEFORE** applying the back upholstery cover. The adjustable back should be checked whenever entering the wheelchair to ensure that the fastening straps are securely fastened.

9. Secure the back upholstery cover (fastening strap) to the back of the adjustable back upholstery (fastening strap).
10. Flip the back upholstery cover over the adjustable back upholstery and secure the fastening straps to the front of the adjustable back upholstery.
11. Lay the front portion of the back upholstery cover on the seat pan.
12. Adjust the slack in the back upholstery cover and then secure to the seat pan fastening straps.

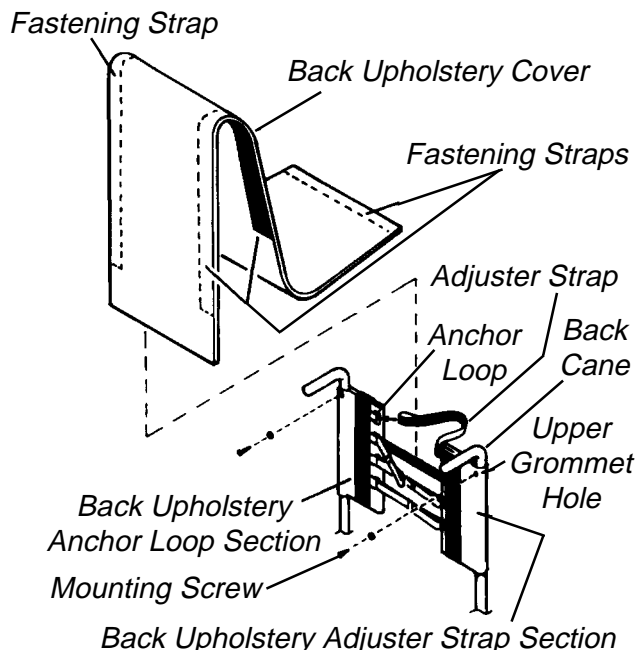
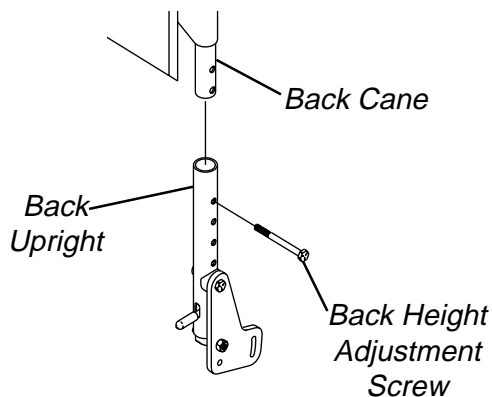

FIGURE 5 - REPLACING CUSTOM MANUAL ADJUSTABLE TENSION BACK UPHOLSTERY

REPLACING THE SPREADER BAR (FIGURE 6)

NOTE: Make sure the spreader bar is ALWAYS attached to the wheelchair.

1. Remove the back height adjustment screws that secure the back canes to the back uprights.
2. Remove the cantilever arms, if necessary. Refer to INSTALLING/REMOVING CANTILEVER ARMS in PROCEDURE 5 of this manual.
3. Loosen, but do not remove the two (2) set screws that secure the EXISTING spreader bar to the back canes.
4. Slide the EXISTING spreader bar off of the two (2) back canes.
5. Slide the NEW spreader bar onto the back canes.
6. Securely tighten the two (2) set screws that secure the NEW spreader bar to the back canes.
7. Reinstall the cantilever arms, if necessary. Refer to INSTALLING/REMOVING CANTILEVER ARMS in PROCEDURE 5 of this manual.
8. Align the mounting hole in each back cane with the desired mounting hole in each back upright.
9. Install the two (2) back height adjustment screws through the back upright mounting holes determined in STEP 8 and the back cane mounting holes.

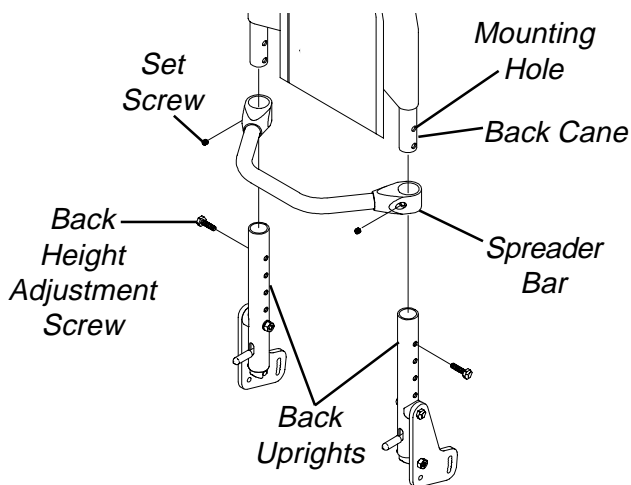

FIGURE 6 - REPLACING THE SPREADER BAR

REPLACING THE LOCKING MECHANISM IN THE BACK CANE (FIGURE 7)

WARNING

The locking mechanism is spring loaded. Place your free hand over the end of the back cane to prevent the locking mechanism from springing out of the back cane.

1. Fold the back down. Refer to FOLDING/UNFOLDING BACK in this procedure of the manual.
2. Unscrew the actuator from the locking mechanism.
3. Remove the locking mechanism and spring from the back cane.

NOTE: Inspect the spring and replace if necessary.

4. Slide the NEW spring and locking mechanism into the back cane.
5. Make sure the angled end of the locking mechanism is at the bottom of the back cane.

NOTE: The long side of the locking mechanism should be toward the actuator opening.

6. Push and hold the locking mechanism into the back cane.
7. Screw the actuator through the actuator opening and into the locking mechanism mounting hole.
8. Unfold the back. Refer to FOLDING/UNFOLDING BACK in this procedure of the manual.

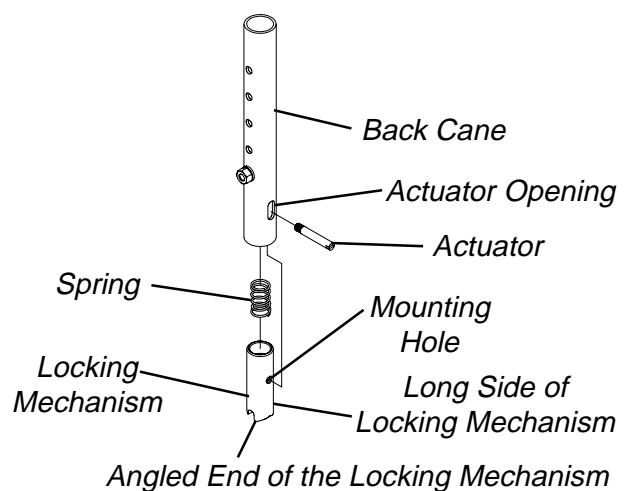

FIGURE 7 - REPLACING THE LOCKING MECHANISM IN THE BACK CANE

INSTALLING THE STROLLER HANDLES (FIGURE 8)

NOTE: If necessary, remove the foam grip on the push handle BEFORE performing this procedure.

1. Slide the stroller handle onto the push handle.
2. Make sure to line up the mounting holes of the stroller handle and the push handle.
3. Press and hold the button on the quick-release pin.
4. While holding the button, insert the quick-release pin through the stroller handle and push handle.
5. Pull on the stroller handle to make sure it is locked securely in place.
6. Repeat STEPS 1-5 for the opposite stroller handle.

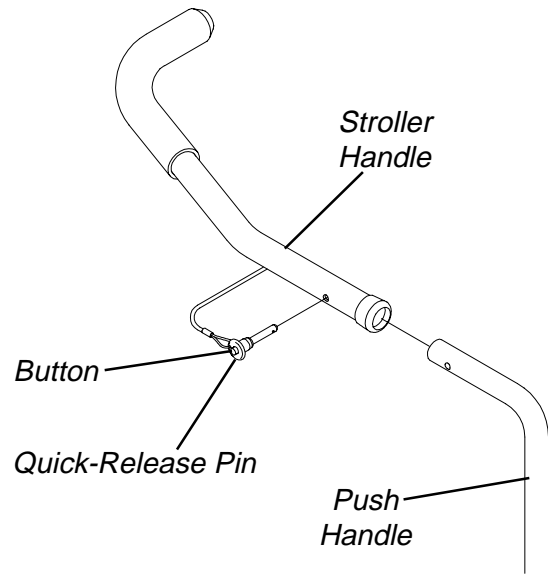

FIGURE 8 - INSTALLING THE STROLLER HANDLES

This Procedure includes the following:**Using Cantilever Arms****Installing/Removing Cantilever Arms****Adjusting Cantilever Arm Height****Adjusting Cantilever Arm Angle****Replacing/Repositioning the Cantilever Arm Locking Mechanism****Arm Pad Adjustment/Replacement****Installing T-Arm Sockets****Installing/Removing T-Arms****Adjusting the T-Arms****Replacing the T-Arm Locking Lever****WARNING**

Never try to lift or tip the wheelchair by the cantilever arms or T-arms, serious injury can occur.

After ANY adjustments, repair or service and BEFORE use, make sure all attachment hardware is tightened securely - otherwise, injury or damage may occur.

USING CANTILEVER ARMS (FIGURE 1)

1. Pull the locking mechanism actuator towards the front of the wheelchair.
2. While holding the actuator, pull UP on the cantilever arm.

NOTE: If cantilever arms rub against rear wheels when UP, increase the wheelbase width. Refer to ADJUSTING WHEELBASE WIDTH in PROCEDURE 7 of this manual.

NOTE: If necessary, the locking mechanism in the cantilever arm can be repositioned so the cantilever arm will flip DOWN instead of UP. Refer to REPLACING/REPOSITIONING THE CANTILEVER ARM LOCKING MECHANISM in this procedure of the manual.

3. To lock the cantilever arm, push DOWN until there is an audible click.
4. Pull UP on the cantilever arm to make sure it is locked in place.

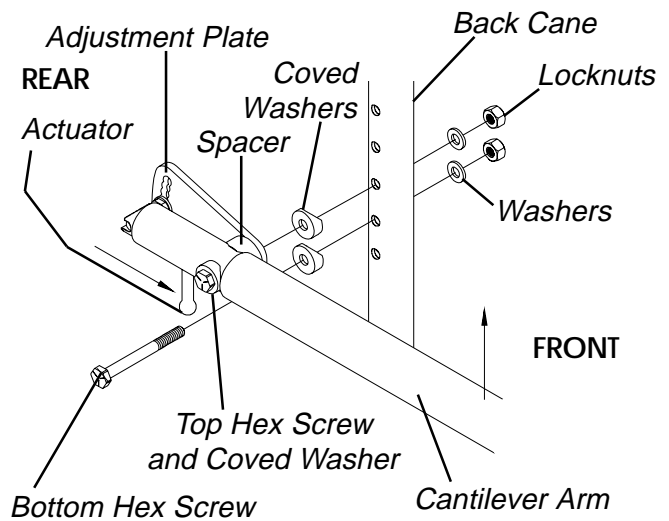

FIGURE 1 - USING CANTILEVER ARMS - INSTALLING/REMOVING CANTILEVER ARMS - ADJUSTING CANTILEVER ARM HEIGHT

INSTALLING/REMOVING CANTILEVER ARMS (FIGURE 1)**Installing**

1. Insert the top hex screw of the partially assembled cantilever arm assembly through the desired back cane mounting hole.

NOTE: The partially assembled cantilever arm assembly includes the top hex screw, coved washers and spacer, adjustment plate and cantilever arm.

NOTE: Make sure the adjustment plate is towards the inside of the wheelchair.

2. Insert the bottom hex screw through the bottom hole of the adjustment plate, the coved washer and the back cane.
3. Secure the cantilever arm to the wheelchair with the washers and locknuts as shown in FIGURE 1.
4. If desired, adjust the angle of the cantilever arm. Refer to ADJUSTING CANTILEVER ARM ANGLE in this procedure of the manual.

Removing

NOTE: When removing the locknuts and washers from the cantilever arm assembly, leave the hex screws, coved washers and spacer in place.

1. Remove the locknuts and washers from the top and bottom hex screws.
2. Remove the cantilever arm assembly from the wheelchair frame.

ADJUSTING CANTILEVER ARM HEIGHT (FIGURE 1)

1. Remove the washers and locknuts from the top hex screw and the bottom hex screw.
2. Pull the cantilever arm assembly with hex screws, spacers, and coved washers away from the back canes.
3. Reposition the cantilever arm assembly and hardware up or down as desired.
4. Insert the two (2) hex screws with hardware and cantilever arm assembly into the desired back cane mounting holes.
5. Secure the cantilever arm to the back canes with the locknuts and washers as shown in FIGURE 1.

ADJUSTING CANTILEVER ARM ANGLE (FIGURES 2 AND 3)

NOTE: This adjustment is recommended if the back angle has been changed.

1. Flip the cantilever arm up and out of the way.
2. Remove the locknut that secures the locking pin to the arm adjustment plate.
3. Refer to FIGURE 3 to determine the mounting hole in the arm adjustment plate that will be used to correspond to the back angle.
4. Securely tighten the locking pin and washer to the adjustment plate with a locknut.
5. Repeat STEPS 1-4 for the opposite side, if necessary.

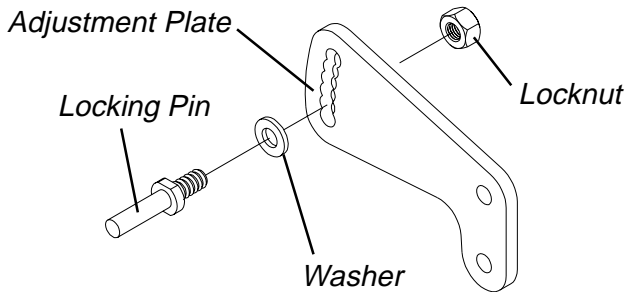

FIGURE 2 - ADJUSTING CANTILEVER ARM ANGLE

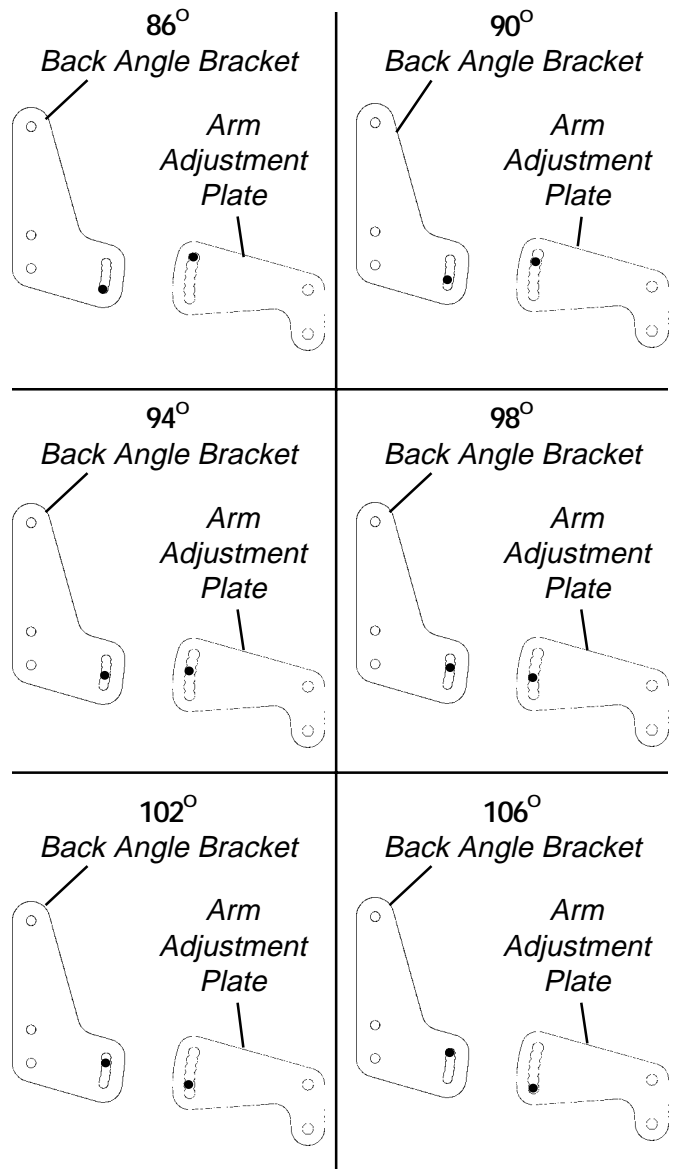

FIGURE 3 - CORRESPONDING ARM ADJUSTMENT TO BACK ANGLE

REPLACING/REPOSITIONING THE CANTILEVER ARM LOCKING MECHANISM (FIGURE 4)

CAUTION

The locking mechanism is spring loaded. Place your free hand over the end of the cantilever arm to prevent the locking mechanism from springing out of the arm.

1. Flip the cantilever arm up and out of the way.
2. Unscrew the actuator from the locking mechanism.
3. Remove the locking mechanism and spring from the cantilever arm.

NOTE: Inspect the spring and replace if necessary.

4. Slide the NEW spring and locking mechanism into the cantilever arm.
5. Position the angled portion of the locking mechanism in one (1) of two (2) ways:
 - A. **ANGLED PORTION FACING UP** - Arm will flip UP.
 - B. **ANGLED PORTION FACING DOWN** - Arm will flip DOWN.
6. Push and hold the locking mechanism into the cantilever arm.
7. Screw the actuator into the locking mechanism mounting hole.
8. Flip the cantilever arm up/down to lock in place.
9. Pull down/up on the cantilever arm to ensure it has locked in place.

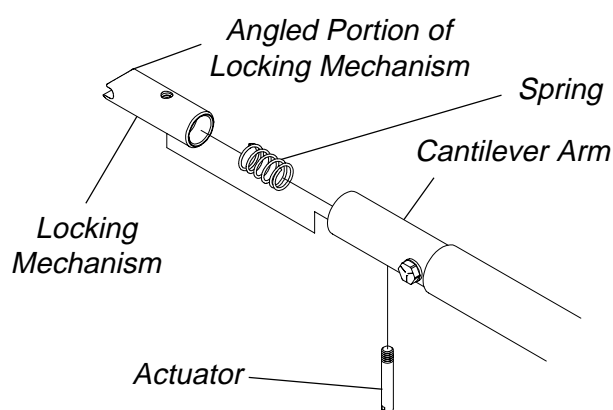

FIGURE 4 - REPOSITIONING/REPLACING THE LOCKING MECHANISM IN THE CANTILEVER ARM

ARMREST PAD ADJUSTMENT/REPLACEMENT (FIGURE 5)

Armrest Pad Adjustment

1. Remove the phillips screw from the rear of the armrest pad.
2. Reposition the cantilever slide tube to one (1) of five (5) positions.
3. Align the mounting hole in the cantilever slide tube with the desired mounting hole from STEP 2.
4. Install the phillips screw UP through the desired mounting hole in the armrest tube and the cantilever slide tube mounting hole to secure the armrest pad to the armrest tube.
5. Repeat STEPS 1-4 for opposite armrest pad if necessary.

Armrest Pad Replacement

1. Remove the phillips screw from the rear of the armrest pad.
2. Remove the phillips screw from the front of the armrest pad.
3. Remove the EXISTING armrest pad from the armrest tube.
4. Position the NEW armrest pad onto the armrest tube and cantilever slide tube.
5. Secure the NEW armrest pad to the armrest tube and cantilever slide tube with the two (2) phillips screws.

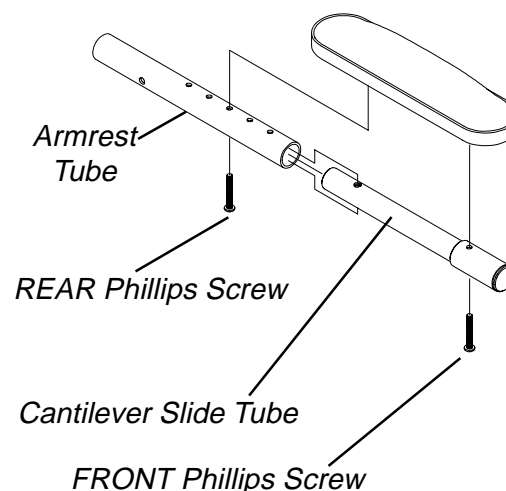

FIGURE 5 - ARMREST PAD ADJUSTMENT/REPLACEMENT

INSTALLING T-ARM SOCKETS (FIGURE 6)

1. Remove rear wheels from wheelchair. Refer to REMOVING/INSTALLING REAR WHEELS in PROCEDURE 7 of this manual.
 2. Position the T-arm clamp on the wheelchair frame as shown in FIGURE 6.
- NOTE: T-arm socket must be positioned on outside of wheelchair frame.*
3. Install hex bolts through T-arm clamp, wheelchair frame and cover washers and tighten securely with locknuts.
 4. Position the T-arm socket inserts in the T-arm socket as shown in FIGURE 6.
 5. Line up the mounting holes in the T-arm socket with the threaded holes in the T-arm clamp.
 6. While holding the T-arm socket and the T-arm clamp together, install the four (4) hex screws and washers into mounting holes and tighten loosely.
 7. Adjust the T-arm socket. Refer to ADJUSTING THE T-ARMS in this procedure of the manual.
 8. Repeat STEPS 2-7 for opposite side of wheelchair.
 9. Install the T-arm into the T-arm sockets in this procedure of the manual.

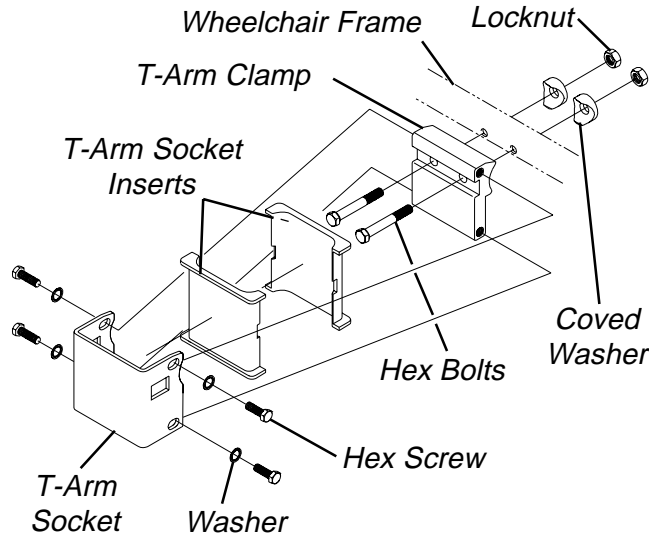

FIGURE 6 - INSTALLING T-ARM SOCKETS

INSTALLING/REMOVING T-ARMS (FIGURE 7)

Installing T-Arms

1. Position the T-arm over the T-arm socket on the wheelchair frame.

NOTE: Make sure the locking lever is towards the front of the wheelchair.

2. Slide T-arm into T-arm socket until the locking lever is in the slot in the T-arm socket and an audible "click" is heard.
3. Pull up on T-arm to make sure T-arm is locked in place.

NOTE: If the T-arm does not slide in the T-arm socket as desired, adjust the T-arm socket. Refer to ADJUSTING THE T-ARMS in this procedure of the manual.

4. Adjust the T-arm for desired height, width and depth, if necessary. Refer to ADJUSTING THE T-ARMS in this procedure of the manual.
5. Repeat STEPS 1-4 for opposite side of wheelchair.

Removing T-Arms

1. Press in on the locking lever and lift the T-arm straight up and out of the T-arm socket.

NOTE: If the T-arm does not slide up and down in the T-arm socket as desired, adjust the T-arm socket. Refer to ADJUSTING THE T-ARMS in this procedure of the manual.

2. Repeat STEP 2 for opposite side of the wheelchair.

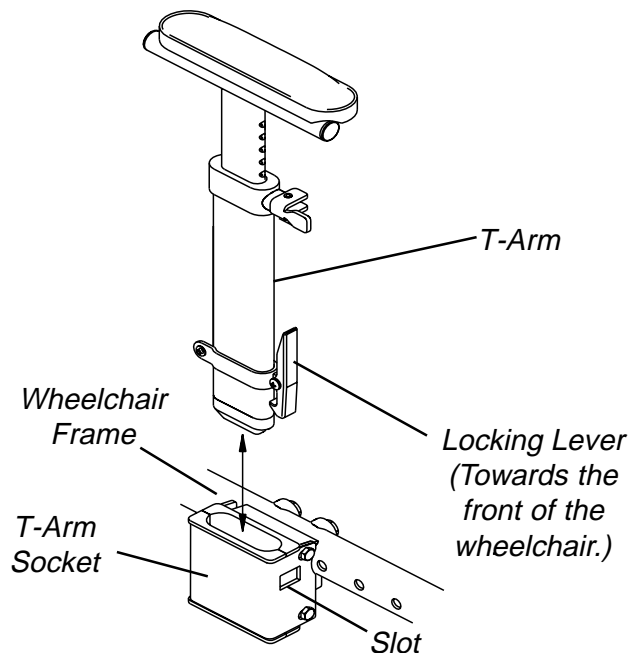

FIGURE 7 - INSTALLING/REMOVING T- ARMS

ADJUSTING THE T-ARMS

Adjusting T-Arm Height (FIGURE 8)

1. Unlock the T-arm by flipping the T-arm release lever towards the inside of the wheelchair.

NOTE: If necessary, pull out on the T-arm release lever and rotate 180° so it can be flipped towards the outside of the wheelchair.

2. Slide the T-arm to one (1) of:
 - A. **Low Height T-Arms** - Nine (9) positions.
 - B. **High Height T-Arms** - Seven (7) positions.

NOTE: If the inside T-arm post does not slide up and down in the outside T-arm post as desired, perform one (1) of the following:

- A. **Tighten** - Tightening the set screws on the outside T-arm post **will make it harder** to move the inside T-arm post up and down.
 - B. **Loosen** - Loosening the set screws on the outside T-arm post **will make it easier** to move the inside T-arm post up and down.
3. Lock the T-arm by flipping the T-arm release lever towards the front of the wheelchair.

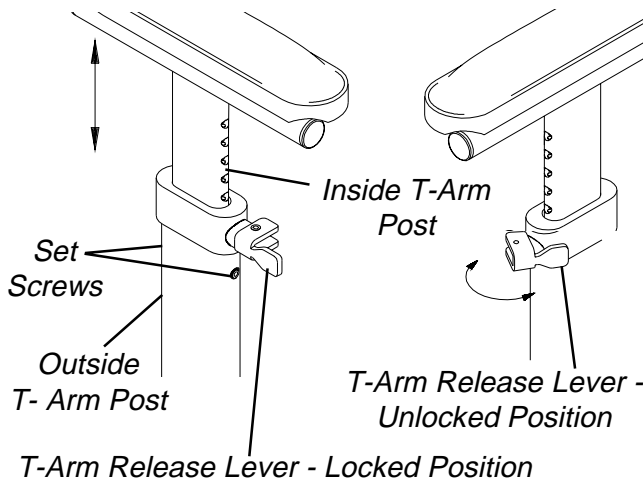

FIGURE 8 - ADJUSTING T-ARM HEIGHT

Adjusting T-Arm Width (FIGURE 9)

1. Remove the two (2) phillips screws that secure the arm pad to the arm tube.
2. Turn the arm pad around and reposition the arm pad on the arm tube.
3. Re-secure the arm pad to the arm tube with the two (2) phillips screws. Tighten securely.
4. Repeat for the opposite side, if necessary.

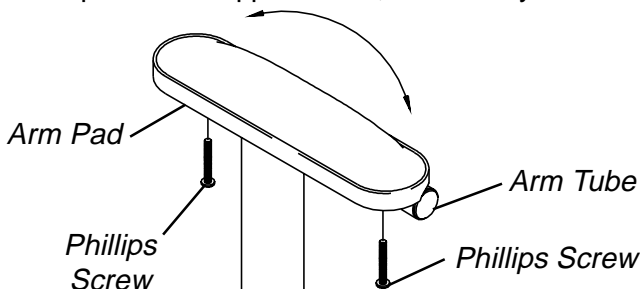

FIGURE 9 - ADJUSTING T-ARM WIDTH

Adjusting T-Arm Depth (FIGURE 10)

1. Remove the two (2) phillips screws that secure the arm pad to the arm tube.
 2. Remove the two (2) socket screws that secure the arm tube to the T-arm post.
 3. Reposition the arm tube on the T-arm post:
 - A. **Desk Length Arms** - to one (1) of three (3) positions depending on the desired arm pad depth.
 - B. **Full Length Arms** - to one (1) of five (5) positions depending on the desired arm pad depth.
- NOTE: Additional positions are obtainable by turning the arm tube 180°.*
4. Re-secure the arm tube to the T-arm post with the two (2) socket screws. Torque to 60-70 in./lbs.
 5. Reattach the arm pad to the arm tube with the two (2) phillips screws. Tighten securely.
 6. Repeat for the opposite side, if necessary.

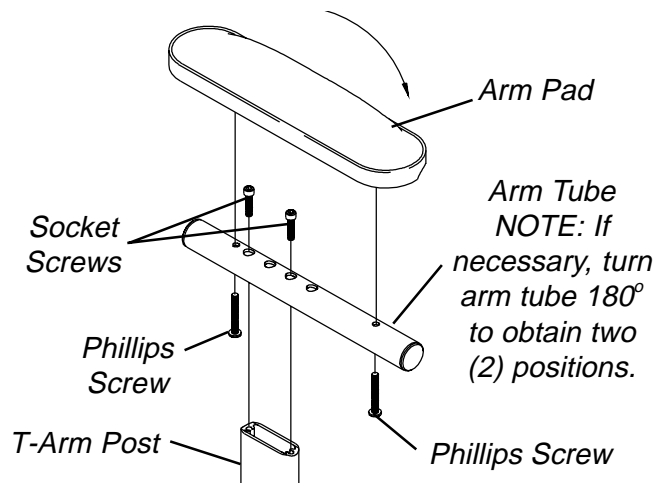

FIGURE 10 - ADJUSTING T-ARM DEPTH

Adjusting T-Arm Sockets (FIGURE 11)

NOTE: Perform this procedure if the T-arm is too loose in the socket or does not easily slide up and down in the socket.

1. Remove the rear wheels from the wheelchair, if necessary. Refer to [REMOVING/INSTALLING REAR WHEELS](#) in PROCEDURE 7 of this manual.
2. Loosen, but do not remove the four (4) hex screws and washers that secure T-arm socket to T-arm clamp.

NOTE: The T-arm socket will disassemble if the four (4) hex screws and washers are removed.

3. Slide the T-arm into the T-arm socket until the locking lever is in the slot in the T-arm socket and an audible "click" is heard.
4. Squeeze the T-arm socket the T-arm clamp together until the socket is flush with the T-arm.
5. While holding the T-arm socket and the T-arm clamp together, tighten the four (4) hex screws and washers. Tighten securely.
6. Press in on the locking lever and lift the T-arm straight up and out of the T-arm socket.
7. Repeat STEPS 3-6, if necessary until the T-arm slides in the T-arm socket as desired.
8. If necessary, install rear wheels. Refer to REMOVING/INSTALLING REAR WHEELS in PROCEDURE 7 of this manual.

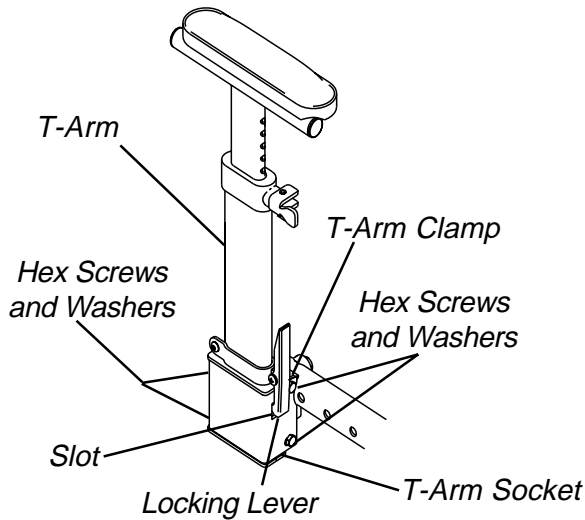

FIGURE 11 - ADJUSTING T-ARM SOCKETS

REPLACING THE T-ARM LOCKING LEVER (FIGURE 12)

1. Remove T-arm from wheelchair. Refer to INSTALLING/REMOVING T-ARMS in this procedure of the manual.
2. Remove the phillips bolt and locknut that secure the EXISTING locking lever to the bottom bracket.

WARNING
 The locking lever is spring loaded. Place your free hand over the locking lever to prevent the parts from springing off of the bottom bracket, otherwise parts may be lost or injury may occur.

3. Remove EXISTING locking lever and spring from bottom bracket.

NOTE: Inspect the spring and replace if necessary.

4. Position spring on bottom bracket as shown in FIGURE 12.
5. Position NEW locking lever onto spring and bottom bracket (DETAIL "A").

NOTE: Make sure the two (2) extended ends of the spring are inside the notch in the locking lever.

6. Line up the mounting holes in the NEW locking lever, spring and bottom bracket.

WARNING
 DO NOT over tighten locknut that secures locking lever to bottom bracket. Over tightening this locknut will prevent locking lever from operating properly, possibly causing injury.

7. Install phillips bolt and tighten securely with locknut.
8. Install the T-arm onto the wheelchair. Refer to INSTALLING/REMOVING T-ARMS in this procedure of the manual.

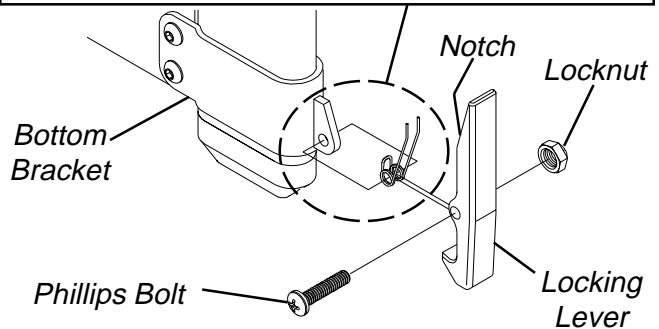
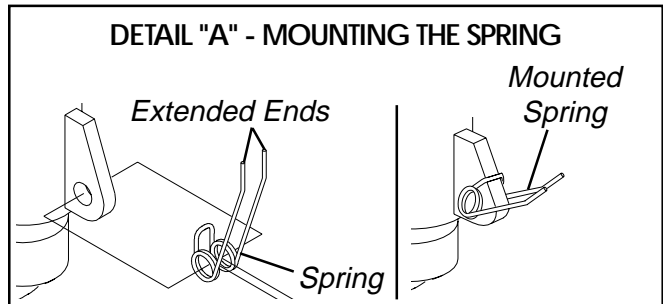

FIGURE 12 - REPLACING THE T-ARM LOCKING LEVER

This Procedure includes the following:

- Replacing Seat Pan
- Adjusting Rear Seat Height
- Adjusting Seat Depth
- Adjusting Seat Width
- Adjusting Front Seat-to-Floor Height

SPACER	HEIGHT DIFFERENCE
NONE	2-inch
1-inch	1-inch
2-inch	NONE

1. Perform STEPS 1-2 of REPLACING THE SEAT PAN.
2. Insert or remove spacers on top of the REAR frame clamps.
3. Perform STEPS 3-4 of REPLACING THE SEAT PAN.

WARNING

After ANY adjustments, repair or service and BEFORE use, make sure all attaching hardware is tightened securely - otherwise injury or damage may result.

ADJUSTING SEAT DEPTH (FIGURES 2 AND 3)

REPLACING SEAT PAN (FIGURE 1)

1. Remove the seat cushion from the seat pan.
2. Remove the four (4) phillips screws, locknuts and spacers (if present) that secure the seat pan to the frame clamps.
3. Position NEW seat pan on wheelchair frame, aligning seat pan mounting holes with frame clamps.
4. Secure the seat pan to the frame clamps with the four (4) phillips screws, locknuts and spacers (if present).

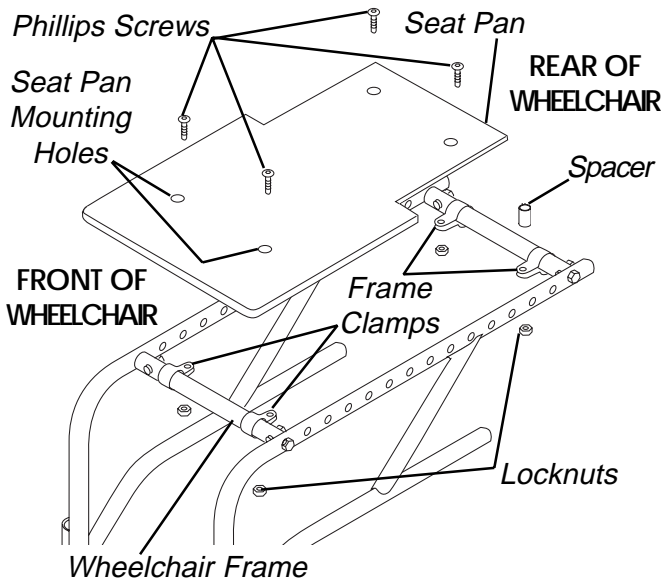

FIGURE 1 - REPLACING SEAT PAN

ADJUSTING REAR SEAT HEIGHT (FIGURE 1)

NOTE: The wheelchair frame is designed to create a 2-inch height difference between the front and the rear of the seat pan. If desired, spacers can be added at the rear of the seat pan to decrease this height difference. Refer to the chart below for the proper spacers.

WARNING

This procedure must be performed by a qualified technician ONLY.

The position of the footrest, camber tube, back angle, the tautness of the back upholstery as well as the user's condition are directly related to the wheelchairs stability. Any change to one (1) or any combination of the five (5) may cause the wheelchair to decrease in stability. Use EXTREME caution when using a new seating position.

NOTE: Note the position of the front hex screw before removing to ensure proper reinstallation.

1. Remove the hex screws, washers, coved spacers and locknuts that secure the back angle brackets to the wheelchair frame.
2. Refer to the chart in FIGURE 3 to determine mounting positions for corresponding seat depths.
3. Position the back assembly with the mounting position determined in STEP 2.
4. Secure the back assembly to the wheelchair frame with the hex screws, washers, coved washers and locknuts. Refer to FIGURE 2 for correct hardware orientation.

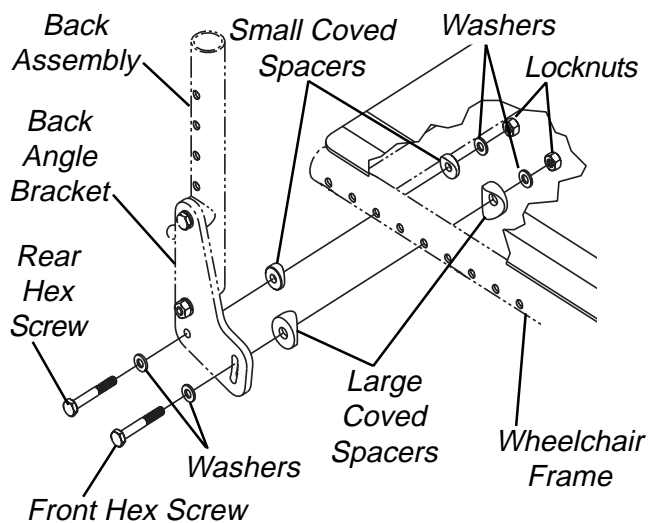
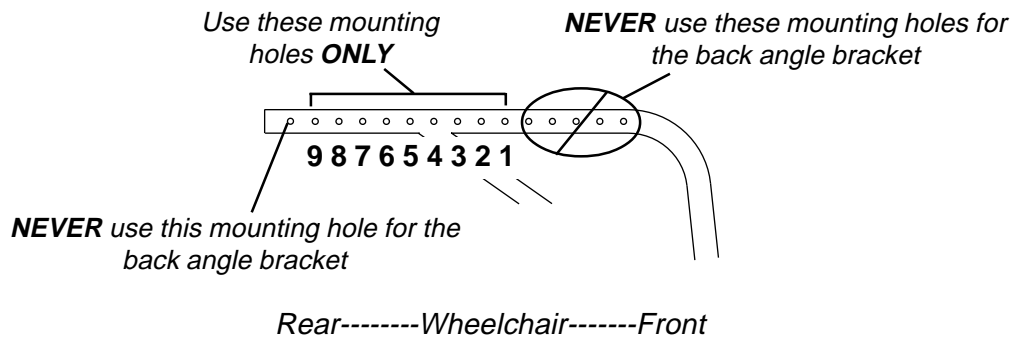

FIGURE 2 - ADJUSTING SEAT DEPTH

PROPER MOUNTING HOLES FOR BACK ANGLE BRACKET



S
E
A
T

SHORT FRAME	LONG FRAME
BACK POSITION FOR 14-INCH SEAT DEPTH Mounting Holes 7 and 9	BACK POSITION FOR 16-INCH SEAT DEPTH Mounting Holes 7 and 9
BACK POSITION FOR 13-INCH SEAT DEPTH Mounting Holes 6 and 8	BACK POSITION FOR 15-INCH SEAT DEPTH Mounting Holes 6 and 8
BACK POSITION FOR 12-INCH SEAT DEPTH Mounting Holes 5 and 7	BACK POSITION FOR 14-INCH SEAT DEPTH Mounting Holes 5 and 7
BACK POSITION FOR 11-INCH SEAT DEPTH Mounting Holes 4 and 6	BACK POSITION FOR 13-INCH SEAT DEPTH Mounting Holes 4 and 6
BACK POSITION FOR 10-INCH SEAT DEPTH Mounting Holes 3 and 5	BACK POSITION FOR 12-INCH SEAT DEPTH Mounting Holes 3 and 5
BACK POSITION FOR 9-INCH SEAT DEPTH Mounting Holes 2 and 4	BACK POSITION FOR 11-INCH SEAT DEPTH Mounting Holes 2 and 4
BACK POSITION FOR 8-INCH SEAT DEPTH Mounting Holes 1 and 3	BACK POSITION FOR 10-INCH SEAT DEPTH Mounting Holes 1 and 3

FIGURE 3 - ADJUSTING SEAT DEPTH

ADJUSTING SEAT WIDTH (FIGURE 4)

WARNING

The following procedure should only be performed by a qualified technician.

1. Remove the EXISTING footplate from the wheelchair. Refer to PROCEDURE 8 of this manual.
2. Remove the EXISTING back upholstery from the wheelchair. Refer to PROCEDURE 4 of this manual.
3. Remove the EXISTING spreader bar from the wheelchair. Refer to REPLACING THE SPREADER BAR in PROCEDURE 4 of this manual.
4. Remove the EXISTING seat pan from the wheelchair. Refer to REPLACING SEAT PAN in this procedure of the manual.

NOTE: Retain the attachment hardware for installation of the NEW seat pan.

5. Remove the axle tube from the wheelchair. Refer to REPLACING AXLE TUBE in PROCEDURE 7 of this manual.
6. Remove the four (4) hex screws and eight (8) coved washers that secure the two (2) EXISTING crossmembers to the wheelchair frame.
7. Remove the four (4) frame clamps from the EXISTING two (2) crossmembers.
8. Install the four (4) frame clamps onto the NEW (2) crossmembers.
9. Secure the two (2) NEW crossmembers to the front and rear mounting holes in the wheelchair frame with the hex screws and coved washers removed in STEP 5.
10. Install the NEW axle tube. Refer to REPLACING AXLE TUBE in PROCEDURE 7 of this manual.
11. Install the NEW seat pan using the EXISTING hardware. Refer to REPLACING SEAT PAN in this procedure of the manual.
12. Install the NEW back upholstery onto the wheelchair. Refer to PROCEDURE 4 of this manual.
13. Install the NEW spreader bar onto the wheelchair. Refer to REPLACING THE SPREADER BAR in PROCEDURE 4 of this manual.
14. Install the NEW footplate onto the wheelchair. Refer to PROCEDURE 8 of this manual.

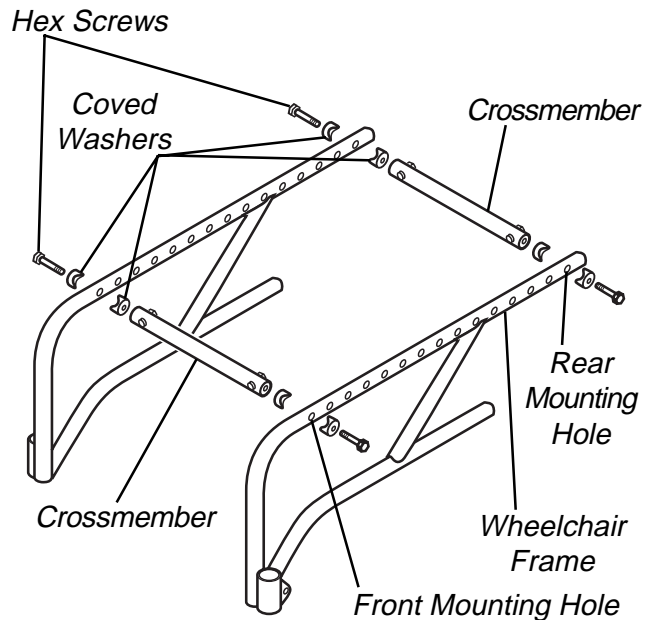

FIGURE 4 - ADJUSTING SEAT WIDTH

ADJUSTING FRONT SEAT-TO-FLOOR HEIGHT

WARNING

The position of the footrest, seat angle, back angle, seating system/upholstery, caster size and position, rear wheel size and position, anti-tippers, as well as the user condition directly relate to the stability of the wheelchair. Any change to one (1) or any combination of the ten (10) may cause the wheelchair to decrease in stability. EXTREME care MUST be taken when changing the stability of the wheelchair. Refer to the chart in STABILITY in PROCEDURE 1 of this manual.

Determining Frame Height (FIGURE 5)

Terminator Jr. Frames come in Short and Tall.

1. To determine frame height, measure from the bottom of the caster headtube to the top of the seat rail.
2. Refer to the chart to determine the frame size.

HEIGHT (INCHES)	FRAME SIZE
7-3/4	SHORT
10-1/2	TALL

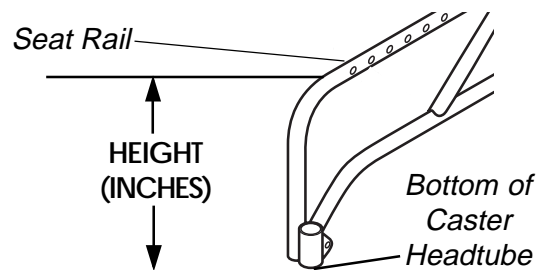

FIGURE 5 - DETERMINING FRAME HEIGHT

Front Seat-to-floor Height Adjustment

NOTE: Refer to STABILITY in PROCEDURE 1 for warnings concerning wheelchair stability.

Seat-to-floor height is determined by measuring from the top of the seat rail to the ground/floor.

The different seat-to-floor heights are possible by using different combinations of rear wheel size and axle tube position.

1. Refer to the chart below to determine available front seat-to-floor heights for each wheelchair frame height.
2. Determine the changes needed to the rear wheels and axle tube by reading across the chart for the seat-to-floor height determined in STEP 1.
3. Refer to REPOSITIONING THE AXLE TUBE in PROCEDURE 7 of the manual to adjust the axle tube position.
4. After adjusting the axle tube, the front casters may need to be repositioned to ensure the caster headtubes are perpendicular to the ground. Refer to ADJUSTING FRONT CASTER HEIGHT in PROCEDURE 7.
5. Anti-tipper height (if applicable) must be adjusted to maintain 1-1/2 to 2-inch clearance between the bottom of the anti-tipper wheels and the floor. Refer to ANTI-TIPPER REPLACEMENT/ADJUSTMENT in PROCEDURE 8 of this manual.
6. Ensure wheel locks engage properly. Refer to WHEEL LOCK ADJUSTMENT/REPLACEMENT in this procedure of the manual.

SEAT

SHORT FRAME SEAT-TO-FLOOR HEIGHTS

FRONT SEAT-TO-FLOOR HEIGHT	AXLE TUBE POSITION			
	REAR WHEEL SIZE (INCHES)			
	18	20	22	24
13-inch	Upper	N/A	N/A	N/A
14-inch	Center	Upper	N/A	N/A
15-inch	Lower	Center	Upper	N/A
16-inch	N/A	Lower	Center	Upper
17-inch	N/A	N/A	Lower	Center
18-inch	N/A	N/A	N/A	Lower

LONG FRAME SEAT-TO-FLOOR HEIGHTS

FRONT SEAT-TO-FLOOR HEIGHT	REAR WHEEL SIZE (INCHES)		
	AXLE TUBE POSITION		
	20	22	24
16-inch	Upper	N/A	N/A
17-inch	Center	Upper	N/A
18-inch	Lower	Center	Upper
19-inch	N/A	Lower	Center
20-inch	N/A	N/A	Lower

NOTE: Rear Seat-to-Floor height is two (2) inches shorter than Front Seat-to-Floor height.

NOTE: The Front Seat-to-Floor heights in the chart are determined using a 5-inch front caster.

NOTE: Refer to REPOSITIONING THE AXLE TUBE in PROCEDURE 7 for an explanation of the Upper, Center and Lower axle tube positions.

- This Procedure includes the following:**
- Removing/Installing Rear Wheels
 - Adjusting Quick-Release Axles
 - Installing Quad-Release Axles
 - Adjusting Quad-Release Handles
 - Handrim Replacement
 - Repairing/Replacing Rear Wheel, Tire/Tube
 - Opening/Closing Clamps
 - Adjusting Rear Wheel Camber
 - Determining/Adjusting Toe in/Toe out
 - Adjusting Wheelbase Length
 - Adjusting Wheelbase Width
 - Replacing Axle Tube
 - Repositioning the Axle Tube
 - Repositioning/Replacing Front Casters
 - Adjusting Front Caster Height
 - Wheel Lock Adjustment/Replacement

WARNING
 After ANY adjustments, repair or service and BEFORE use, make sure all attaching hardware is tightened securely - otherwise injury or damage may result.

REMOVING/INSTALLING REAR WHEELS (FIGURE 1)

CAUTION
 Changing the size of the rear wheels can affect the performance of the wheelchair. Contact Invacare at the telephone numbers on the back of this manual BEFORE changing rear wheel size.

1. Perform one (1) of the following:
QUICK-RELEASE - Push in the tip of the quick-release axle and pull axle and wheel away from the wheelchair.
QUAD-RELEASE - Lift UP on the handle of the quad-release axle and pull axle and wheel away from the wheelchair.
2. Repeat STEP 1 for the opposite rear wheel.
3. Reinstall the rear wheels onto the wheelchair by reversing STEPS 1-2.

WARNING
 Pull on the rear wheel to make sure the detent pin and locking pins of the quick/quad-release axle are fully released BEFORE operating wheelchair. Keep locking pins clean.

WARNING
 During contact activities, Invacare recommends inserting quick-release axles with the head end to the inside of the wheelchair to prevent accidental release.

5. If there is too much movement of the rear wheel assembly in a back and forth motion, refer to ADJUSTING QUICK-RELEASE AXLES or ADJUSTING QUAD-RELEASE HANDLES in this procedure of the manual.

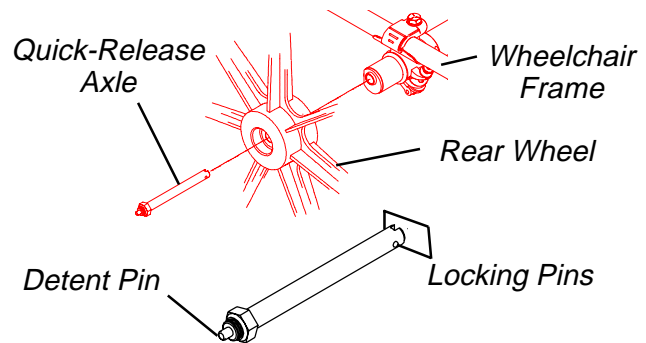

NOTE: Quad-Release Axle not shown. Locking pins the same as Quick-Release Axle

FIGURE 1 - REMOVING/INSTALLING REAR WHEELS

ADJUSTING QUICK-RELEASE AXLES (FIGURE 2)

1. Remove rear wheel and quick-release axle from the wheelchair. Refer to REMOVING/INSTALLING REAR WHEELS in this procedure of the manual.
2. Depress detent pin in the quick-release axle and slide axle through the wheel hub.
3. Release detent pin ensuring that the locking pins are fully released.
4. Increase or decrease end play by adjusting the locknut on the end of the quick-release axle.
5. Reinstall rear wheel onto the wheelchair. Refer to REMOVING/INSTALLING REAR WHEELS in this procedure of the manual.

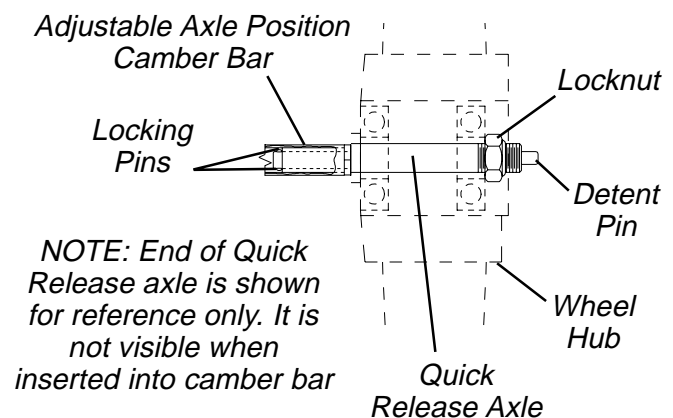

NOTE: End of Quick Release axle is shown for reference only. It is not visible when inserted into camber bar

FIGURE 2- ADJUSTING QUICK-RELEASE AXLES

INSTALLING QUAD-RELEASE AXLES (FIGURE 3)

1. Remove rear wheel and the EXISTING quick-release axle from the wheelchair. Refer to REMOVING/INSTALLING REAR WHEELS in this procedure of the manual.
2. Remove EXISTING quick-release axle from rear wheel.
3. Insert NEW quad-release axle through rear wheel hub.
4. Slide locking collar onto quad-release axle until it is snug against rear wheel and tighten securely with allen screw.
5. Reinstall rear wheel and the quad-release axle onto the wheelchair. Refer to REMOVING/INSTALLING REAR WHEELS in this procedure of the manual.
6. Flip the handle of the quad-release axle down to release the detent pin ensuring that the locking pins are fully released.
7. If detent pin does not fully release, proceed to ADJUSTING QUAD-RELEASE HANDLE IN AND/OR OUT in this procedure of the manual.
8. Repeat STEPS 1-7 for the opposite rear wheel.

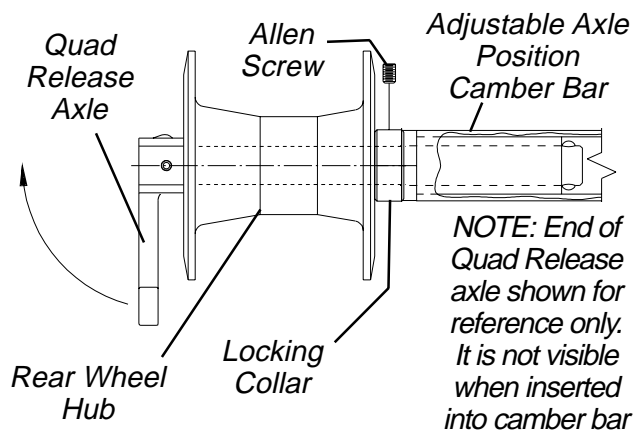

FIGURE 3 - INSTALLING QUAD-RELEASE AXLES

ADJUSTING QUAD-RELEASE HANDLES (FIGURE 4)

In and/or Out

1. Remove rear wheel and the quad-release axle from the wheelchair. Refer to REMOVING/INSTALLING REAR WHEELS in this procedure of the manual.
2. Loosen the locking screw.

3. Make the following adjustments:
 - If the quad-release handle is **not releasing the locking pins completely**, rotate the quad-release handle approximately **one-quarter (1/4) turn CLOCKWISE**.
 - If the quad-release handle **hits the spokes** of the rear wheel when assembled, rotate the **quad-release handle** approximately **one-quarter (1/4) turn COUNTERCLOCKWISE**.
4. Tighten the locking screw.
5. Reinstall the rear wheel and quad-release axle onto the wheelchair. Refer to REMOVING/INSTALLING REAR WHEELS in this procedure of the manual.
6. Flip the handle of the quad-release axle down to release the detent pin ensuring that the locking pins are fully released.
7. Repeat the above procedures until the quad-release axle locks correctly.

Removing Play From Rear Wheels

NOTE: The adjusting locknut on the quick-release axles originally performed this function.

1. With the rear wheel and quad-release axle still mounted onto the wheelchair, make the following adjustment:
 - Tighten the length adjusting screw** until there is **no in and out movement** of the **quad-release axle and rear wheel**.

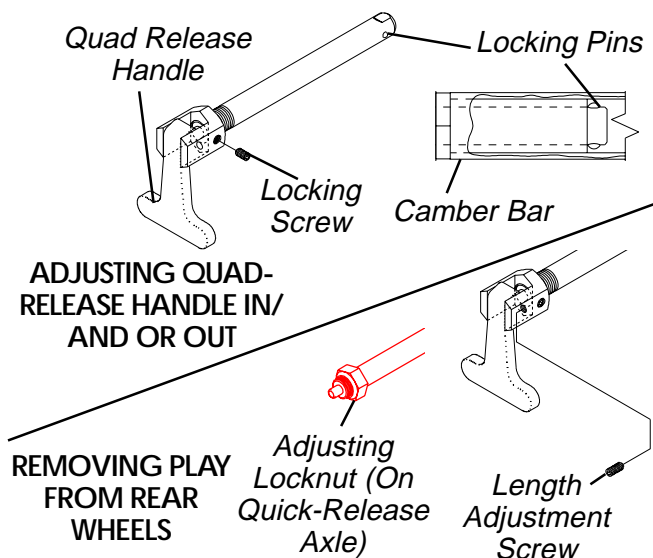

FIGURE 4 - ADJUSTING QUAD-RELEASE HANDLES

HANDRIM REPLACEMENT (FIGURE 5)

1. Remove the rear wheel from the wheelchair. Refer to REMOVING/INSTALLING REAR WHEELS in this procedure of the manual.

WARNING

Tire **MUST** be **FULLY** deflated **BEFORE** any disassembly procedures are performed. Otherwise injury or damage may result.

2. Remove all air from the tube by pressing down on the pin in the center of the valve stem.
3. While carefully holding the tire, tube and rim strip to one side, hold the allen screws and remove the locknuts that secure the handrim to the rear wheel.
4. Remove the **EXISTING** handrim.
5. Install **NEW** handrim by reversing **STEPS 2-4**.

WARNING

DO NOT inflate tire until it is completely assembled. Otherwise injury or damage may result.

6. Inflate tire to correct psi rating on the sidewall of tire.
7. Reinstall rear wheel to the wheelchair. Refer to **REMOVING/INSTALLING REAR WHEELS** in this procedure of the manual.
8. Repeat **STEPS 1-7** for opposite rear wheel if necessary.

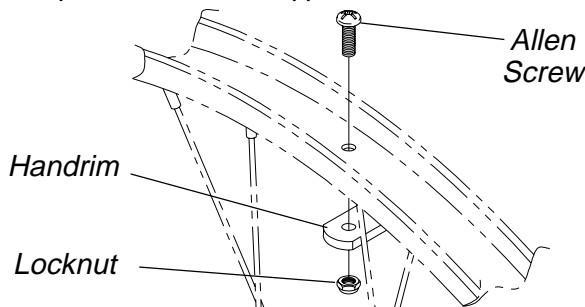

FIGURE 5 - HANDRIM REPLACEMENT

REPAIRING/REPLACING REAR WHEEL, TIRE/TUBE

WARNING

Replacement of the tire or tube **MUST** be performed by a qualified technician.

CAUTION

Changing the size of the rear wheels can affect the performance of the wheelchair. Contact Invacare at the numbers on the back cover **BEFORE** performing this procedure.

*NOTE: If replacing rear wheels with a different size than what was originally on the wheelchair, the front caster height must also be changed to keep the wheelchair frame parallel to the floor. Refer to **ADJUSTING FRONT CASTER HEIGHT** in this procedure of the manual **ONLY** after contacting Invacare. Anti-tipper height (if applicable) must also be adjusted to maintain 1-1/2 to 2-inch clearance between bottom of the anti-tipper wheels and the floor. Refer to **ANTI-TIPPER REPLACEMENT/ADJUSTMENT** in **PROCEDURE 8** of this manual.*

OPENING/CLOSING CLAMPS (FIGURE 6)

WARNING

QUICK RELEASE LEVERS - Make sure the quick release levers are in the **CLOSED** position **BEFORE** using the wheelchair, otherwise personal injury or damage to the wheelchair may result.

STANDARD CAMBER OR RECEIVER TUBE CLAMPS - Make sure the hex screws and locknuts are securely tightened **BEFORE** using the wheelchair, otherwise personal injury or damage to the wheelchair may result.

CAUTION

DO NOT close the quick-release levers or tighten the hex screws and locknuts without camber inserts in the axle tube. Damage to the axle tube will occur.

Camber Clamps

1. Perform one (1) of the following to open a camber clamp:
 - A. **QUICK RELEASE LEVERS** - Pull the quick release lever to the open position.
 - B. **STANDARD CAMBER CLAMPS** - Loosen, but do not remove the hex screw and locknut on the camber clamp.
2. Perform one (1) of the following to close a camber clamp:
 - A. **QUICK RELEASE LEVERS** - Push the quick release lever on the camber clamps to the closed position.
 - B. **STANDARD CAMBER CLAMPS** - Securely tighten the hex screw and locknut to secure the axle tube.

Receiver Tube Clamps

*NOTE: The receiver tube clamps are used **ONLY** to adjust wheelbase length.*

1. Perform one (1) of the following to open a receiver tube clamp:
 - A. **QUICK RELEASE LEVERS** - Pull the quick release levers on the receiver tube clamps to the open position.
 - B. **STANDARD RECEIVER TUBE CLAMPS** - Loosen, but do not remove the hex screws and locknuts on the receiver tube clamps.
2. Perform one (1) of the following to close a receiver tube clamp:
 - A. **QUICK RELEASE LEVERS** - Push the quick release lever on the receiver tube clamps to the closed position.
 - B. **STANDARD RECEIVER TUBE CLAMPS** - Tighten the hex screw and locknut on the receiver tube clamp.

WHEELS

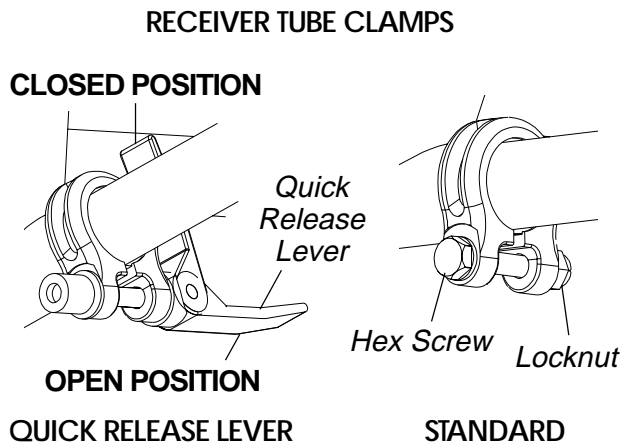
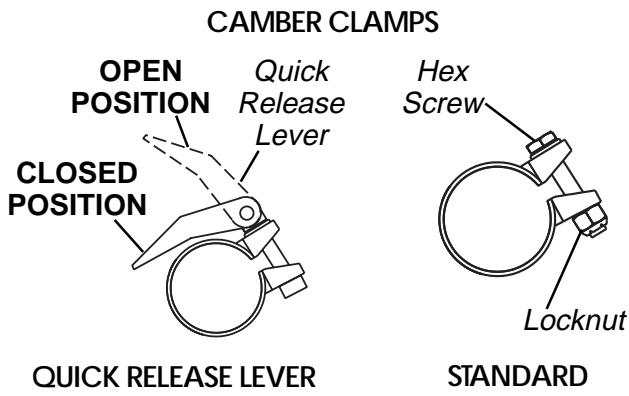

FIGURE 6 - OPENING/CLOSING CLAMPS

ADJUSTING REAR WHEEL CAMBER (FIGURE 7)

NOTE: Perform this procedure to one (1) side of the wheelchair at a time for ease of adjustment.

1. Open the camber clamps. Refer to OPENING/CLOSING CLAMPS in this procedure of the manual.
2. Pull one (1) rear wheel with camber insert out of axle tube.
3. Remove the rear wheel from the camber insert.
4. Rotate the camber insert 180°.
5. Reinstall the rear wheel into the camber insert.

6. Position the camber insert to the desired position. Make sure there is no more than 3-inches (12 indexing marks) of the camber inserts outside of the axle tube.
7. Slide the indexing ring on the camber insert until it is flush with the camber clamp.

NOTE: Before using the wheelchair, make sure both camber inserts are set to the same indexing mark. This will make sure the distance between the rear wheel and the wheelchair is the same on both sides.

WARNING

QUICK RELEASE LEVERS - Make sure the quick release levers are pointing towards the rear of the wheelchair and are in the **CLOSED** position **BEFORE** using the wheelchair, otherwise personal injury or damage to the wheelchair may result.

STANDARD - Make sure the hex screws and locknuts are securely tightened **BEFORE** using the wheelchair, otherwise personal injury or damage to the wheelchair may result.

8. Close the camber clamps. Refer to OPENING/CLOSING CLAMPS in this procedure of the manual.
9. Repeat STEPS 1-8 for opposite side of wheelchair.
10. Reinstall rear wheel to the wheelchair. Refer to REMOVING/INSTALLING REAR WHEELS in this procedure of the manual.
11. Adjust toe in/toe out of wheelchair. Refer to DETERMINING/ADJUSTING TOE IN/TOE OUT in this procedure of the manual.

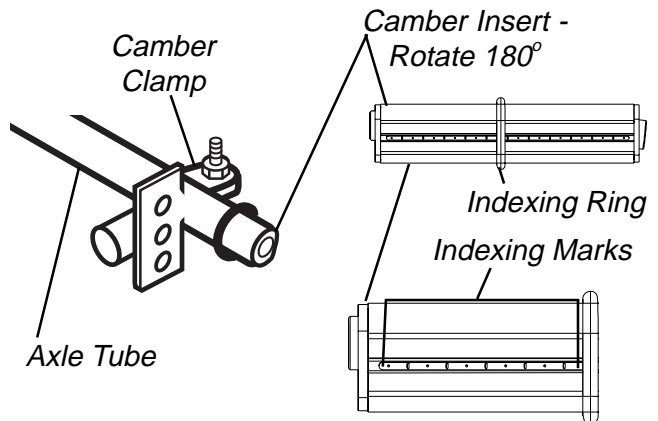

FIGURE 7 - ADJUSTING REAR WHEEL CAMBER

WARNING

NEVER position the camber inserts in the axle tube with more than 3-inches (12 indexing marks showing) of the camber insert outside of the axle tube. The camber inserts will not be securely tightened in the axle tube resulting in possible injury to the user and/or damage to the wheelchair.

DETERMINING/ADJUSTING TOE IN/TOE OUT

Determining Toe In/Toe Out (FIGURES 8 AND 9)

- Inflate all pneumatic tires to recommended tire pressures (listed on the sidewall of the tire).

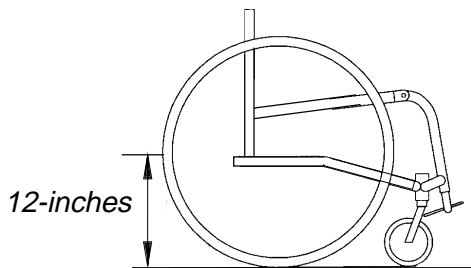

FIGURE 8 - DETERMINING TOE IN/TOE OUT - MEASURING CENTERLINES OF REAR WHEELS

- Measure the distance between the centerlines at the rear and front of the rear wheels at approximately 12-inches from the ground/floor (FIGURE 8).

NOTE: For optimum accuracy, perform STEP 2 with the wheelchair occupied.

- Determine difference between two (2) measurements. If **difference** between the **two (2) measurements** is **GREATER** than **1/2-inch (0 ± 1/4-inch for maximum rollability)**, one (1) of two (2) conditions exists:
 - If the **rear centerline measurement** of the rear wheels is **SMALLER** than the **front centerline measurement** of the rear wheels, a **TOE-OUT** condition exists (FIGURE 9).
 - If the **rear centerline measurement** of the rear wheels is **LARGER** than the **front centerline measurement** of the rear wheels, a **TOE-IN** condition exists (FIGURE 9).
- If the difference between the measurements is greater than 1/2-inch, correct the toe-in/toe-out condition. Proceed to ADJUSTING TOE-IN/TOE-OUT in this procedure of the manual.

FRONT OF WHEELCHAIR

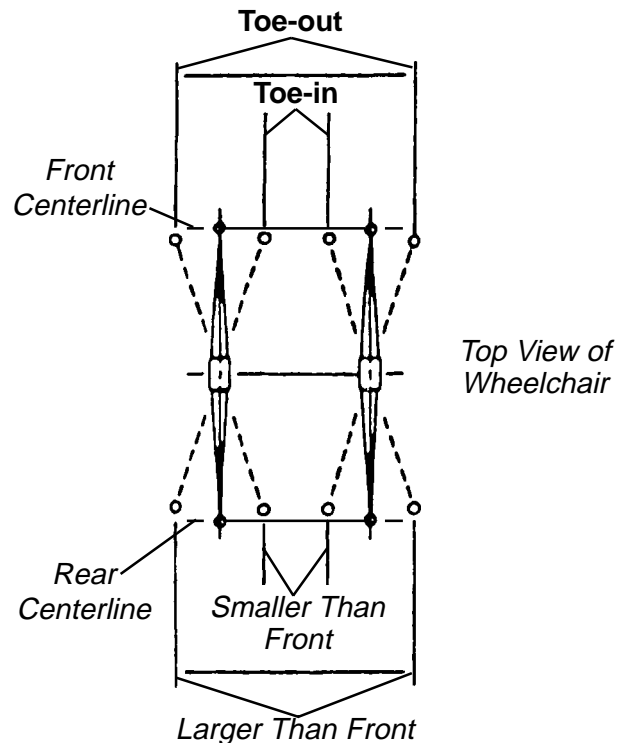

FIGURE 9 - DETERMINING TOE IN/TOE OUT - COMPARING CENTERLINE MEASUREMENTS OF REAR WHEELS

Adjusting Toe In/Toe Out (FIGURE 10)

NOTE: This procedure is required any time the axle tube is moved from the factory set position or is replaced.

NOTE: Make the following adjustment for one (1) camber at a time.

- Open the camber clamps. Refer to OPENING/CLOSING CLAMPS in this procedure of the manual.
- Slowly rotate the axle tube **CLOCKWISE** or **COUNTERCLOCKWISE** until the rear wheels are approximately in a straight line.

WARNING

QUICK RELEASE LEVERS - Make sure the quick release levers are pointing towards the rear of the wheelchair and are in the **CLOSED** position **BEFORE** using the wheelchair, otherwise personal injury or damage to the wheelchair may result.

STANDARD - Make sure the hex screws and locknuts are securely tightened **BEFORE** using the wheelchair, otherwise personal injury or damage to the wheelchair may result.

- Close the camber clamps. Refer to OPENING/CLOSING CLAMPS in this procedure of the manual.

4. Measure the distance between the center lines at the rear and front of the rear wheels at approximately 12-inches from the ground/floor. Refer to **DETERMINING TOE IN/TOE OUT** in this procedure of the manual.
5. Repeat STEPS 1-4 until the toe in/toe out measurement is less than 1/2-inch ($0 \pm 1/4$ -inch for maximum rollability).

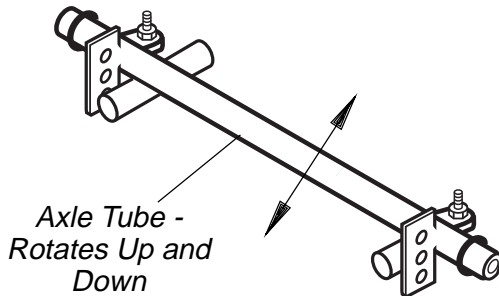

NOTE: Rear wheels removed from the drawings for clarity, There is no need to remove rear wheels from the wheelchair during adjustment.

FIGURE 10 - ADJUSTING TOE IN/TOE OUT

ADJUSTING WHEELBASE LENGTH (FIGURE 11)

WARNING

Always perform this procedure in the presence of an assistant. The position of the footrest, camber tube, back angle, the tautness of the back upholstery as well as the user's condition are directly related to the wheelchairs stability. Any change to one (1) or any combination of the five (5) may cause the wheelchair to decrease in stability. Use **EXTREME** caution when using a **NEW** seating position.

1. Open both receiver tube clamps. Refer to OPENING/CLOSING CLAMPS in this procedure of the manual.

WARNING

Telescoping tubes have two types of marks - "0" and "X" (DETAIL "A"). "X" marks are provided to indicate that the telescoping tube has been extended too far. **DO NOT** adjust the telescoping tubes so any "X" marks are showing. Otherwise, injury or damage may occur.

2. Perform one (1) of the following:
 - A. **PULL** telescoping tubes out of receiver tubes to **LENGTHEN THE WHEELBASE**, increase stability and maintain standard maneuverability of the wheelchair.
 - B. **PUSH** telescoping tubes into receiver tubes to **SHORTEN THE WHEELBASE**, increase the maneuverability, distribute additional weight onto the rear wheels and decrease the stability of the wheelchair.

NOTE: Marks on the telescoping tubes have been provided to ensure the telescoping tubes are aligned with each other. The performance of the wheelchair will be affected if the two (2) telescoping tubes are not adjusted to the same position. Refer to FIGURE 11.

WARNING

QUICK RELEASE LEVERS - Make sure the quick release levers are pointing towards the inside of the wheelchair and is in the **CLOSED** position **BEFORE** using the wheelchair, otherwise personal injury or damage to the wheelchair may result.

STANDARD - Make sure the hex screws and locknuts are securely tightened **BEFORE** using the wheelchair, otherwise personal injury or damage to the wheelchair may result.

CAUTION

Do not close the quick-release levers or tighten the hex screws and locknuts without telescoping tubes into the receiver tubes. Damage to the receiver tubes will occur.

3. Close both receiver tube clamps. Refer to OPENING/CLOSING CLAMPS in this procedure of the manual.
4. Roll the wheelchair before using to make sure there is no excessive drag to either side.

NOTE: If drag to either side occurs, refer to DETERMINING/ADJUSTING TOE IN/TOE OUT in this procedure of the manual.

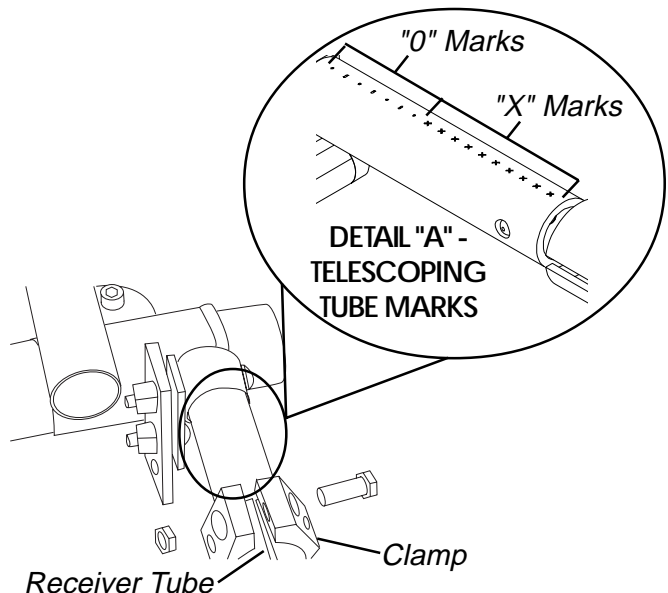

FIGURE 11 - ADJUSTING WHEELBASE LENGTH

ADJUSTING WHEELBASE WIDTH (FIGURE 12)

NOTE: Perform this procedure one (1) side of the wheelchair at a time for ease of adjustment.

1. Open the camber clamps. Refer to OPENING/CLOSING CLAMPS in this procedure of the manual.

WARNING

NEVER position the camber inserts in the axle tube with more than 3-inches (12 indexing marks showing) of the camber insert outside of the axle tube. The camber inserts will not be securely tightened in the axle tube resulting in possible injury to the user or damage to the wheelchair.

2. Position camber insert to the desired position. Make sure there is no more than 3-inches (12 indexing marks showing) of the camber inserts outside of the axle tube.
3. Slide the indexing ring on the camber insert until it is flush with the camber clamp.

NOTE: Before using the wheelchair, make sure both camber inserts are set at the same indexing mark. This will make sure the distance between the rear wheel and the wheelchair is the same on both sides.

WARNING

QUICK RELEASE LEVERS - Make sure the quick release levers are pointing towards the rear of the wheelchair and are in the **CLOSED** position **BEFORE** using the wheelchair, otherwise personal injury or damage to the wheelchair may result.

STANDARD - Make sure the hex screws and lock-nuts are securely tightened **BEFORE** using the wheelchair, otherwise personal injury or damage to the wheelchair may result.

4. Close the camber clamps. Refer to OPENING/CLOSING CLAMPS in this procedure of the manual.
5. Repeat STEPS 1-4 for opposite side of wheelchair.

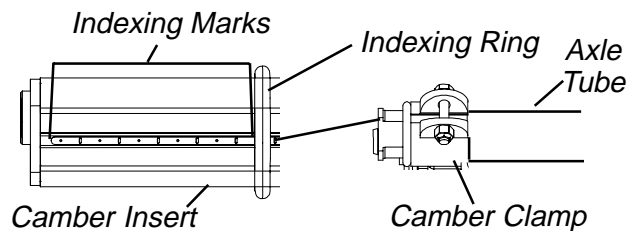

FIGURE 12 - ADJUSTING WHEELBASE WIDTH

REPLACING AXLE TUBE (FIGURE 13)

NOTE: There is no need to remove the two (2) camber clamps when replacing the axle tube.

1. Note the position of the camber inserts so they can be installed to the original position in the **NEW** axle tube.
2. Open the camber clamps. Refer to OPENING/CLOSING CLAMPS in this procedure of the manual.
3. Remove the two (2) rear wheels and camber inserts positioned in the axle tube.
5. Pull the **EXISTING** axle tube through one (1) of the camber clamps.
7. Pull the **EXISTING** axle tube through the other camber clamp and remove from the wheelchair.
8. Slide the **NEW** axle tube through one (1) of the camber clamps. Make sure the notches in the axle tube are towards the rear of the wheelchair and the slots in the axle tube are facing up.

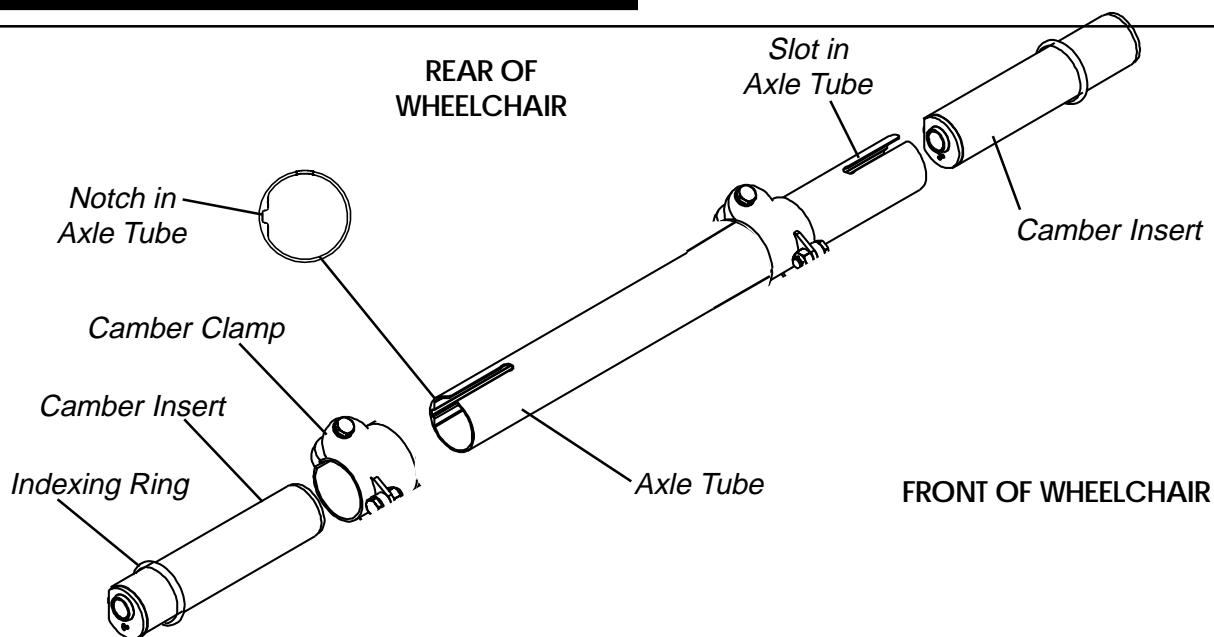

FIGURE 13 - REPLACING AXLE TUBE

- Slide the NEW axle tube through the other camber clamp until the end of the axle tube is flush with the outside of the camber clamp.

NOTE: DO NOT close the quick release levers or tighten the hex screws that secure the axle tube to the camber clamps at this time.

WARNING

NEVER position the camber inserts in the axle tube with more than 3-inches (12 indexing marks showing) of the camber insert outside of the axle tube. The camber inserts will not be securely tightened in the axle tube resulting in possible injury to the user or damage to the wheelchair.

- Install the rear wheels and camber inserts into the NEW axle tube and slide the camber inserts to the position noted in STEP 1. Make sure there is no more than 3-inches (12 indexing marks) of the camber inserts outside of the axle tube.
- Slide the indexing ring on the camber insert until it is flush with the camber clamp

NOTE: To maximize rollability: Before using the wheelchair, make sure both camber inserts are set to the same indexing notch. This will make sure the distance between the rear wheel and the wheelchair is the same on both sides.

- Adjust the toe-in/toe-out of the wheelchair. Refer to DETERMINING/ADJUSTING TOE-IN/TOE-OUT in this procedure of the manual.

NOTE: The performance of the wheelchair will be affected if the axle tube has not been adjusted to correct the toe in/toe out of the wheelchair.

- Ensure the camber clamps are closed. Refer to OPENING/CLOSING CLAMPS in this procedure of the manual.

REPOSITIONING THE AXLE TUBE (FIGURES 14 AND 15)

NOTE: This procedure should only be performed if changing the front seat-to-floor height. Refer to ADJUSTING FRONT SEAT-TO-FLOOR HEIGHT in PROCEDURE 6 of this manual.

NOTE: Right and left are determined by standing behind the wheelchair.

- Remove the rear wheels from the wheelchair. Refer to REMOVING/INSTALLING REAR WHEELS in this procedure of the manual.
- Position the wheelchair on a flat surface with the underside facing UP.
- Refer to ADJUSTING FRONT SEAT-TO-FLOOR HEIGHT in PROCEDURE 6 of the manual to determine the proper position for the axle tube.
- Refer to the chart in FIGURE 15 to determine the proper axle tube adjustment.

NOTE: Refer to DETAIL "B" of FIGURE 15 for telescoping tube and camber clamp mounting hole patterns.

- Remove the locknuts and hex bolts securing the telescoping tube mounting plate to the camber clamps mounting plate.
- Perform one (1) of the following:
 - CLAMP POSITION MUST BE REVERSED** - Proceed to STEP 6.
 - CLAMP POSITION REMAINS IN STANDARD POSITION** - proceed to STEP 11.
- Loosen the hex screw securing the telescoping tube clamp.
- Remove the RIGHT telescoping tube wheelchair frame and set aside.
- Remove the LEFT telescoping tube from the wheelchair frame.
- Insert the LEFT telescoping tube into the RIGHT side of the wheelchair frame with the mounting plate towards the INSIDE of the wheelchair.
- Repeat STEP 9 for the RIGHT telescoping tube and the LEFT side of the wheelchair frame.
- Align the camber clamp mounting plate holes with the telescoping tube mounting plate holes determined in STEP 5.
- Install the long hex screw through the telescoping tube and the camber clamp mounting plate.
- Install the short hex screw through the telescoping tube mounting plate and the camber clamp mounting plate.
- Secure both hex screws with the two (2) locknuts.
- Install the rear wheels. Refer to REMOVING/INSTALLING REAR WHEELS in this procedure of the manual.
- Ensure the caster headtubes are perpendicular to the ground. Adjust caster height if necessary. Refer to ADJUSTING FRONT CASTER HEIGHT in this procedure of the manual.
- Adjust anti-tippers. Refer to ANTI-TIPPER ADJUSTMENT/REPLACEMENT in PROCEDURE 8 of the manual.

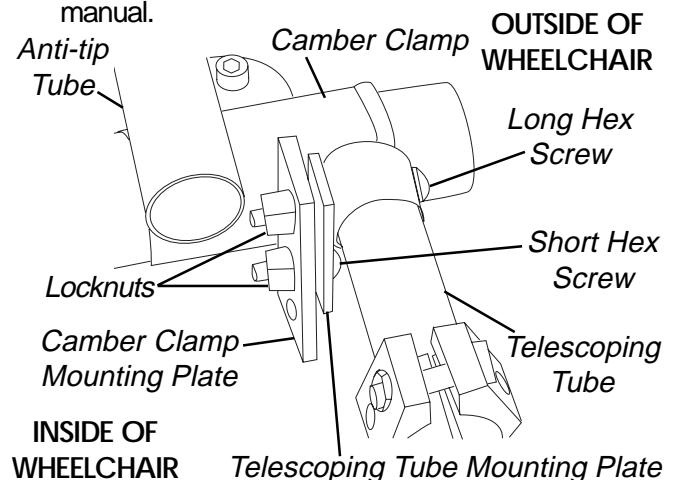

FIGURE 14 - REPOSITIONING THE AXLE TUBE

AXLE TUBE POSITIONS							
AXLE POSITION	CLAMP HOLE	TELESCOPING TUBE HOLE	TUBE POSITION	AXLE POSITION	CLAMP HOLE	TELESCOPING TUBE HOLE	TUBE POSITION
UPPER	1 2	B A	STANDARD	CENTER	3 2	A B	STANDARD
AXLE POSITION	CLAMP HOLE	TELESCOPING TUBE HOLE	TUBE POSITION	AXLE POSITION	CLAMP HOLE	TELESCOPING TUBE HOLE	TUBE POSITION
LOWER	2 3	A B	REVERSED	CENTER	1 2	A B	REVERSED

NOTE: Right camber clamp and telescoping shown as viewed with the wheelchair's underside facing up.

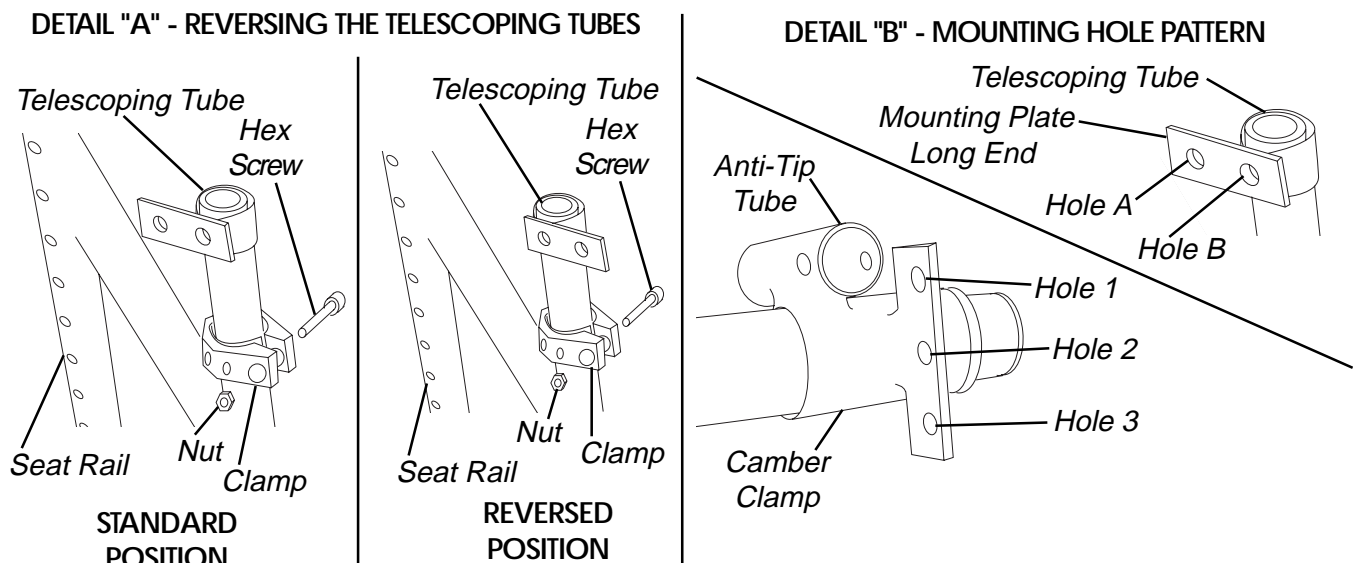

FIGURE 15 - REPOSITIONING THE AXLE TUBE

REPOSITIONING/REPLACING FRONT CASTERS (FIGURE 14)

CAUTION

Replacing/repositioning the front casters can affect the performance of the wheelchair. Contact Invacare at the telephone numbers on the back of this manual BEFORE performing this procedure.

Replacing Front Casters

NOTE: Both casters should be the same size.

1. Remove the bolt and locknut that secure the front caster to the fork.
2. Remove front caster and axle spacers from fork.
3. Install NEW front caster and spacers onto the fork and securely tighten with the bolt and locknut.
4. Repeat STEPS 1-3 for opposite front caster if necessary.

NOTE: WHEELCHAIRS WITH STANDARD FORKS: If replacing front casters with a different size than what was originally on the wheelchair, the front caster height **MUST** be adjusted to keep the wheelchair frame parallel to the floor. Refer to ADJUSTING FRONT CASTER HEIGHT in this procedure of the manual **ONLY** after contacting Invacare.

NOTE: WHEELCHAIRS WITH SUSPENSION FORKS: If replacing front casters with a different size than what was originally on the wheelchair, the front caster height **MUST** be adjusted to keep the wheelchair frame parallel to the floor. Proceed to REPOSITIONING FRONT CASTERS in this procedure of the manual.

Repositioning Front Casters

NOTE: This procedure is for wheelchairs with suspension forks ONLY.

1. Remove the bolt and locknut that secure the caster and axle spacers to the fork.
2. Install the caster, bolt, locknut and axle spacers onto the fork in the desired mounting position. Tighten securely.
3. Repeat STEPS 1-2 for the opposite caster if necessary.

*NOTE: If the casters have been repositioned and the wheelchair frame is not parallel to the floor, the caster height **MUST** be adjusted. Refer to ADJUSTING FRONT CASTER HEIGHT in this procedure of the manual.*

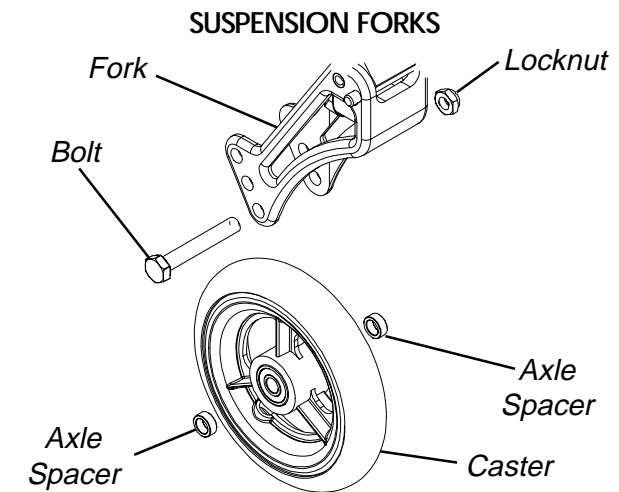
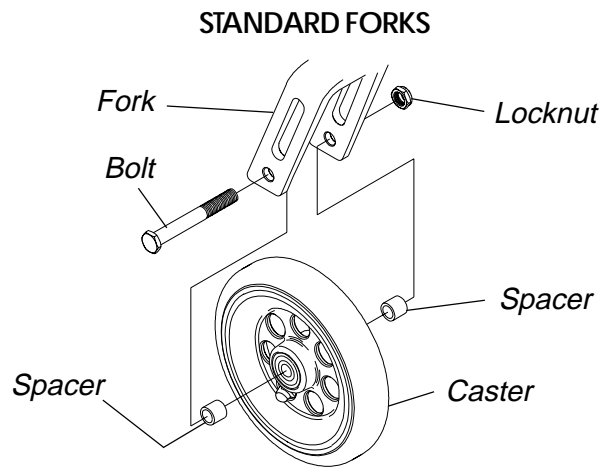

FIGURE 14 - REPOSITIONING/REPLACING FRONT CASTERS

ADJUSTING FRONT CASTER HEIGHT (FIGURE 15)

CAUTION

Changing the height of the front casters can affect the performance of the wheelchair. Contact Invacare at the telephone numbers on the back of this manual BEFORE performing this procedure.

NOTE: When changing the seat-to-floor height, the rear wheel/front caster size and/or the original degree of camber of the wheelchair, it becomes necessary to adjust the front caster height so the wheelchair frame will remain parallel to the floor.

1. Place the wheelchair on a flat surface.
2. Loosen the locknut securing the caster headtube.
3. Position a large right triangle or "L" square on the flat surface and against the caster headtube.
4. Adjust the height of the front caster by sliding the fork stem up or down until the caster headtube is flush against the right triangle or "L" square.

5. Tighten the hex screw securing the caster headtubes.
6. Repeat STEPS 2-5 on the opposite front caster.

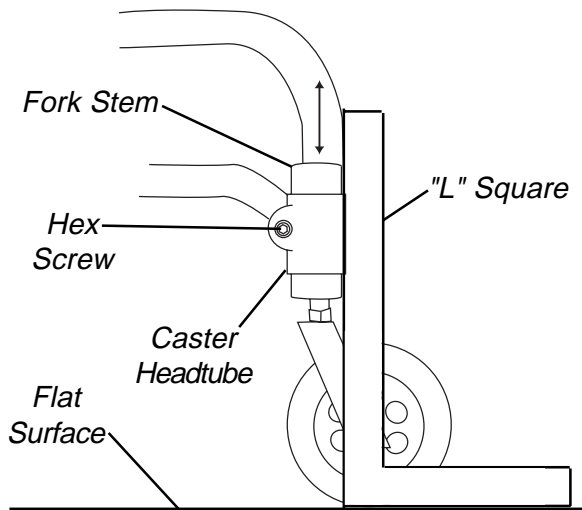

FIGURE 15 - ADJUSTING FRONT CASTER HEIGHT

**WHEEL LOCK ADJUSTMENT/
REPLACEMENT (FIGURE 16)**

NOTE: Before adjusting or replacing the wheel locks, ensure that the tires are inflated to the recommended psi on the sidewall of the tire.

1. Loosen the two (2) hex screws on the clamp that secures the wheel lock to the side frame.
2. Perform one (1) of the following:

Replacing the Wheel Lock:

- A. Slide the wheel lock mounting bar out of the clamp.
- B. Insert the NEW wheel lock mounting bar into the clamp and proceed to adjusting the wheel lock.

Adjusting the Wheel Lock:

- A. Engage the wheel lock.
- B. Measure the distance the wheel lock is embedded into the tire as shown in FIGURE 16.
NOTE: Any wheel lock adjustment should embed the wheel lock shoe at least 3/16-inch into the tire when engaged.
- C. If necessary, loosen the two (2) hex screws on the wheel lock clamp and reposition the wheel lock.
- D. Tighten the two (2) hex screws on the wheel lock clamp to secure the wheel lock.
- E. Repeat steps A-D until the measurement is at least 3/16-inch and holds the wheelchair in position.
- F. Repeat this procedure for the opposite wheel lock.

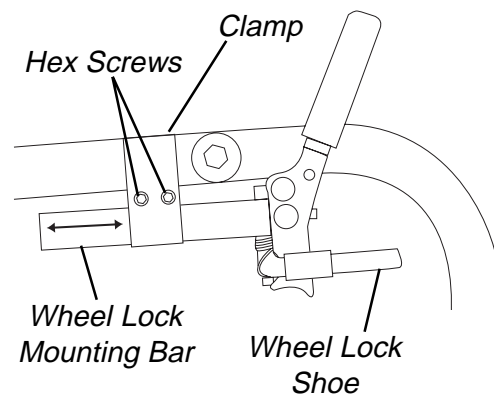

WHEEL LOCK ENGAGEMENT

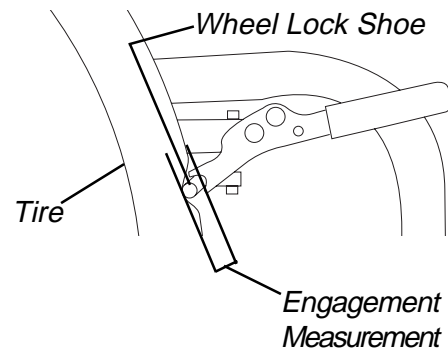

FIGURE 16 - WHEEL LOCK ADJUSTMENT/
REPLACEMENT

WHEELS

This Procedure includes the following:
Adjusting/Replacing Flip-Up Footboard
Adjusting/Replacing Rigid Tubular Footrest
Anti-Tipper Replacement/Adjustment

WARNING
 After ANY adjustments, repair or service and BEFORE use, make sure all attaching hardware is tightened securely - otherwise injury or damage may result.
 ALWAYS perform this procedure in the presence of an assistant. The position of the footrest, camber tube, back angle, the tautness of the back upholstery as well as the user's condition are directly related to the wheelchairs stability. Any change to one (1) or any combination of the five (5) may cause the wheelchair to decrease in stability. Use EXTREME caution when using a new seating position.
 Check ALL Allen Screws that secure the footrest/raised footrest system to the wheelchair frame to make sure they are securely tightened BEFORE using the wheelchair. ESPECIALLY if engaging in ANY vigorous activity.
 The footrest assembly MUST be at least 1-3/4-inches above the ground/floor to avoid hitting protruding objects when using this wheelchair.

ADJUSTING/REPLACING FLIP-UP FOOTBOARD (FIGURE 1)

Adjusting Flip-Up Footboard

DEPTH.

1. Loosen the two (2) hex screws on each clamp securing the footboard to the wheelchair.
2. Slide the footboard mounting bar to the desired position.
3. Securely tighten the two (2) hex screws on each clamp securing the footboard to the wheelchair.

HEIGHT.

1. Remove the hex bolts, locknuts, and covered washers securing the footboard to the footboard mounting bar.
2. Reposition the footboard to the desired height.
3. Install the hex bolts, locknuts and covered washers through the footboard and footboard mounting bar as shown in FIGURE 1.

ANGLE.

1. Flip the footboard up.
2. Torque the angle adjustment screws:
IN (COUNTERCLOCKWISE) - to angle the footboard downward.
OUT (CLOCKWISE) - to angle the footboard upward.

NOTE: Ensure that both angle adjustment screws have the same number of threads showing.

3. Flip the footboard down.

Replacing Flip-Up Footboard

1. Loosen the two (2) hex screws on each clamp securing the footboard to the wheelchair.
2. Slide the EXISTING footboard mounting bars out of the clamps.
3. Slide the NEW footboard mounting bars into the clamps on the wheelchair frame.
4. Tighten the two (2) hex screws on the clamps to secure the footboard mounting bars to the wheelchair frame.

ADJUSTING DEPTH AND HEIGHT/REPLACING

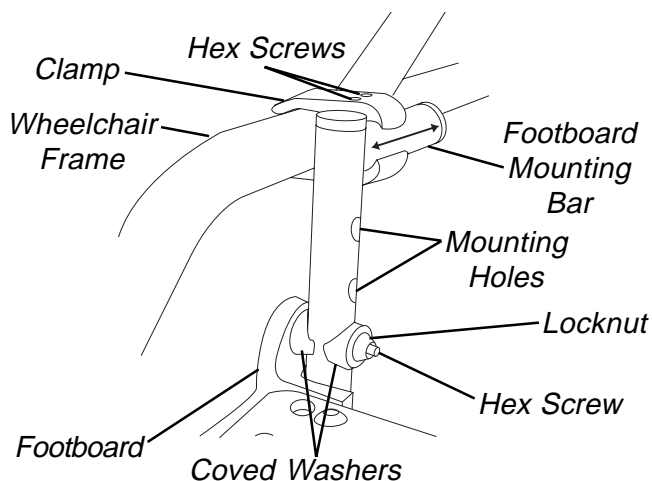

ADJUSTING ANGLE

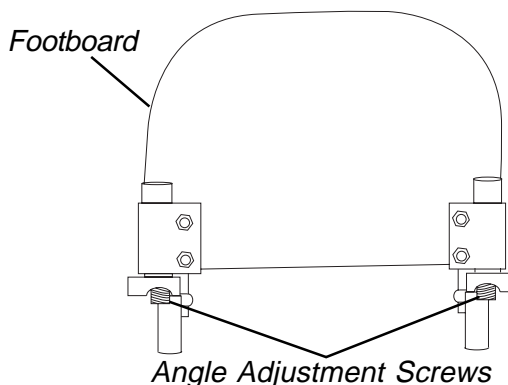

FIGURE 1 - ADJUSTING/REPLACING FLIP-UP FOOTBOARD

ADJUSTING/REPLACING RIGID TUBULAR FOOTREST (FIGURE 2)

1. Loosen the two (2) Allen Screws that secure the footrest to the wheelchair frame.

If Replacing the Footrest:

1. Remove EXISTING and install NEW footrest.

WARNING

The standard footrest has an open hoop. A footplate cover is recommended for wheelchair users that have leg spasticity or whose feet have a possibility of falling through the footrest hoop. A calf strap is provided with each wheelchair to prevent the feet from slipping backwards off of the footrest. Be sure the calf strap is secure when using the wheelchair.

If Replacing or Adjusting the Footrest:

1. Position NEW/EXISTING footrest to desired height.
2. Tighten the two (2) Allen Screws that secure the footrest to the wheelchair frame.

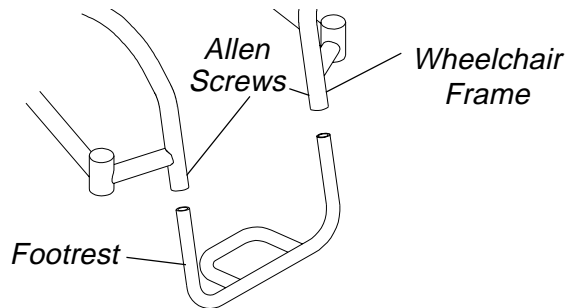

FIGURE 2 - ADJUSTING/REPLACING STANDARD FOOTREST

ANTI-TIPPER REPLACEMENT/ADJUSTMENT (FIGURE 3)

Replacement

1. Press in the two (2) push pins that secure the EXISTING anti-tipper bar to the anti-tipper socket.
2. Remove the anti-tipper bar from the anti-tipper socket.
4. Insert the NEW anti-tipper bar into the anti-tipper socket.

5. Ensure the push pins are fully engaged in the mounting holes of the anti-tipper socket.
6. Repeat STEPS 1-5 for the opposite anti-tipper if necessary.

Adjustment

NOTE: If the rear wheel size is changed or the position of the adjustable axle camber bar is changed, the anti-tippers MUST be readjusted to maintain a 1-1/2 to 2-inch clearance between the bottom of anti-tipper wheels and floor.

1. Press the push pin securing the anti-tipper extension to the anti-tipper bar.
2. Position the anti-tipper extension to one (1) of four (4) mounting holes which allow a 1-1/2 to 2-inch clearance of the wheels to the floor.

NOTE: A 1-1/2 to 2-inch clearance between the bottom of the anti-tipper wheels and the floor must be maintained.

8. Ensure the push pin is fully engaged in the anti-tipper extension mounting hole.
9. Repeat procedure for opposite anti-tipper if necessary.

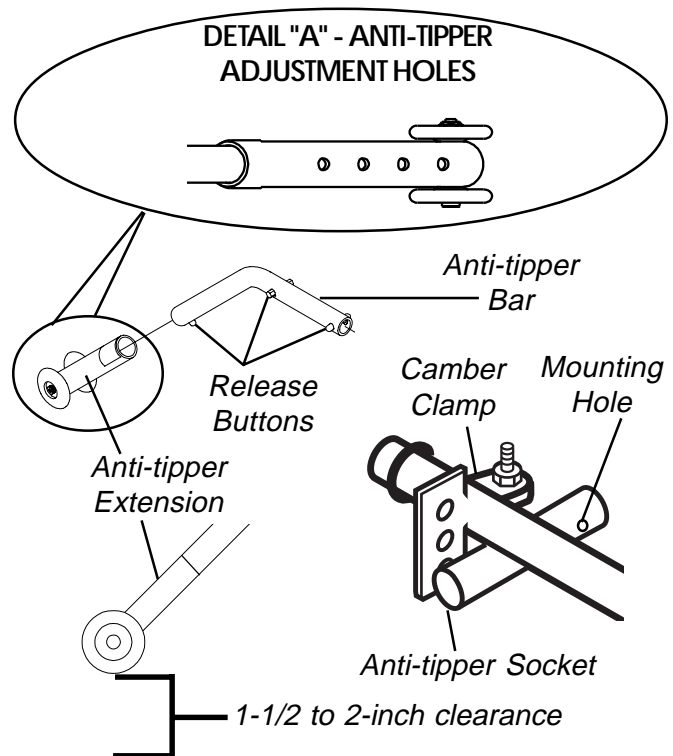

FIGURE 3 - ANTI-TIPPER ADJUSTMENT/REPLACEMENT

FOOTREST

ANTI-TIPPER

This Procedure includes the following:
Elastomers and Suspension
Replacing Front Elastomers

WARNING
 After ANY adjustments, repair or service and BEFORE use, make sure all attaching hardware is tightened securely - otherwise injury or damage may result.

NOTE: The following procedures are for wheelchair with front suspension forks only.

ELASTOMERS AND SUSPENSION

CAUTION
 Weather conditions may affect elastomers. Invacare recommends that elastomers be replaced once a year, otherwise the performance of the wheelchair may be affected.

NOTE: The performance of the wheelchair will be affected if elastomers ARE NOT the same on BOTH SIDES of the wheelchair.

NOTE: If elastomers squeak, lubricate the ends of the elastomers with a silicone based lubricant.

REPLACING FRONT ELASTOMERS (FIGURE 1)

WARNING
 Ensure the detent ball protrudes past the fork BEFORE use. Otherwise, injury or damage may occur.

1. Remove the bolt and locknut securing the fork to the fork stem.
2. Remove the EXISTING elastomer from the fork.
3. Position one end of the NEW elastomer into the fork stem recess and the other end into the fork recess (DETAIL "A").

NOTE: Ensure the ends of the elastomer sit flush in the fork and fork stem recesses.

4. Hold and squeeze the fork and fork stem together (DETAIL "B").
5. Insert the bolt through the mounting holes in the fork to secure the elastomer to the fork.

NOTE: The bolt should be inserted from the OUTSIDE of the wheelchair, so the locknut will be on the INSIDE of the wheelchair.

6. Install the locknut onto the bolt and securely tighten.

NOTE: Caster not shown for clarity.

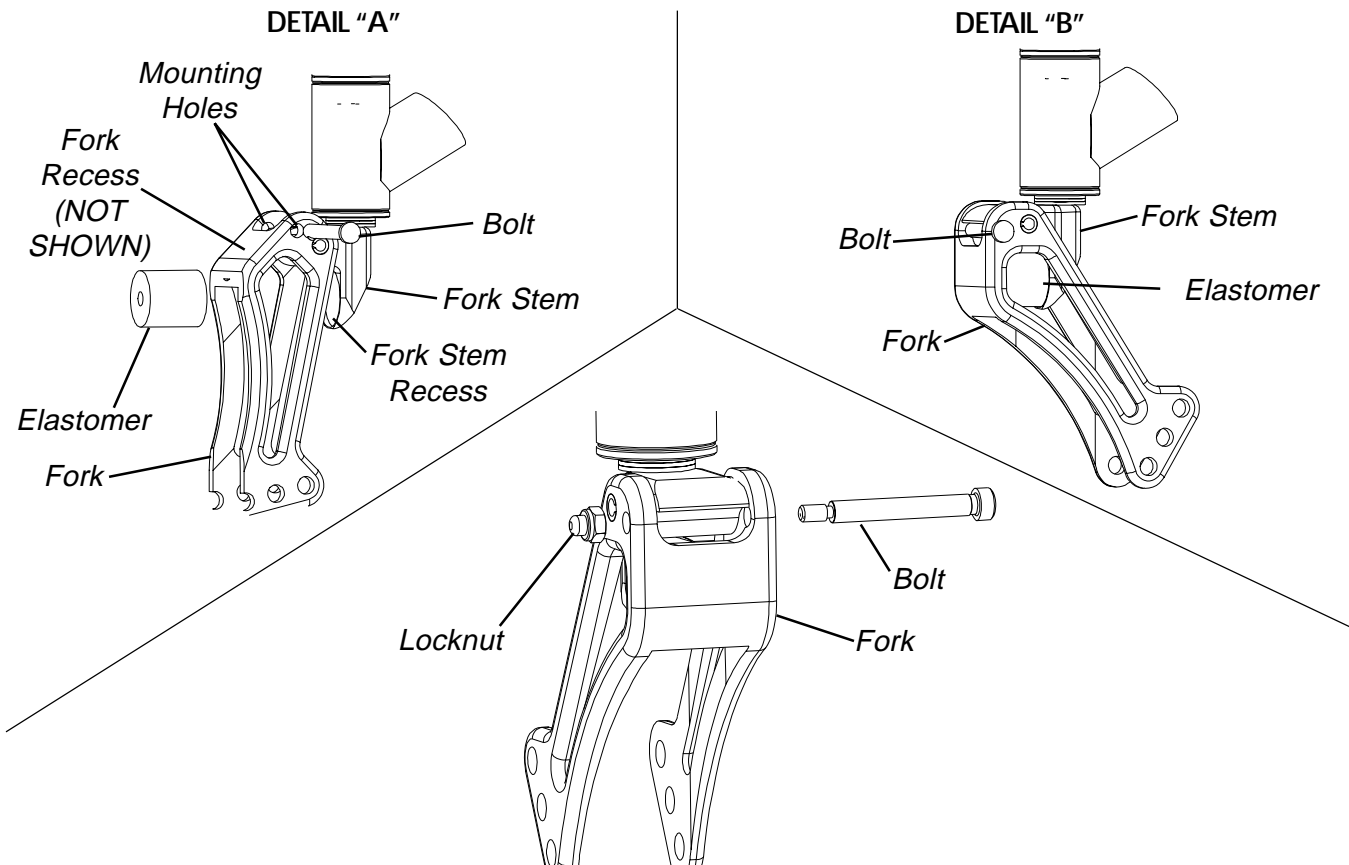

FIGURE 1 - REPLACING FRONT ELASTOMERS

NOTES

**N
O
T
E
S**

LIMITED WARRANTY

PLEASE NOTE: THE WARRANTY BELOW HAS BEEN DRAFTED TO COMPLY WITH FEDERAL LAW APPLICABLE TO PRODUCTS MANUFACTURED AFTER JULY 4, 1975.

This warranty is extended only to the original purchaser/user of our products.

This warranty gives you specific legal rights and you may also have other legal rights which vary from state to state.

Invacare warrants the Terminator Jr. sideframes to be free from defects in materials and workmanship for a lifetime of the original purchaser from the date of purchase. All component parts including, but not limited to camber tubes, caster forks, armrests and upholstery are warranted against defects in materials and workmanship for a period of one (1) year from the date of purchase except push handle grips, bushings, bearings, and tires/tubes. If within such warranty period any such product shall be proven to be defective, such product shall be repaired or replaced, at Invacare's option. This warranty does not include any labor or shipping charges incurred in replacement part installation or repair of any such product. Invacare's sole obligation and your exclusive remedy under this warranty shall be limited to such repair and/or replacement.

For warranty service, please contact the dealer from whom you purchased your Invacare product. In the event you do not receive satisfactory warranty service, please write directly to Invacare Top End at the address on the back cover. Provide dealer's name, address, date of purchase, indicate nature of the defect and, if the product is serialized, indicate the serial number. Do not return products to our factory without our prior consent.

LIMITATIONS AND EXCLUSIONS: THE FOREGOING WARRANTY SHALL NOT APPLY TO SERIAL NUMBERED PRODUCTS IF THE SERIAL NUMBER HAS BEEN REMOVED OR DEFACED, PRODUCTS SUBJECTED TO NEGLIGENCE, ACCIDENT, IMPROPER OPERATION, MAINTENANCE OR STORAGE, COMMERCIAL OR INSTITUTIONAL USE, PRODUCTS MODIFIED WITHOUT INVACARE'S EXPRESS WRITTEN CONSENT (INCLUDING, BUT NOT LIMITED TO, MODIFICATION THROUGH THE USE OF UNAUTHORIZED PARTS OR ATTACHMENTS; PRODUCTS DAMAGED BY REASON OF REPAIRS MADE TO ANY COMPONENT WITHOUT THE SPECIFIC CONSENT OF INVACARE, OR TO A PRODUCT DAMAGED BY CIRCUMSTANCES BEYOND INVACARE'S CONTROL, AND SUCH EVALUATION WILL BE SOLELY DETERMINED BY INVACARE. THE WARRANTY SHALL NOT APPLY TO PROBLEMS ARISING FROM NORMAL WEAR OR FAILURE TO ADHERE TO THESE INSTRUCTIONS.

THE FOREGOING WARRANTY IS EXCLUSIVE AND IN LIEU OF ALL OTHER EXPRESS WARRANTIES. IMPLIED WARRANTIES, IF ANY, INCLUDING THE IMPLIED WARRANTIES OF MERCHANTABILITY AND FITNESS FOR A PARTICULAR PURPOSE, SHALL NOT EXTEND BEYOND THE DURATION OF THE EXPRESS WARRANTY PROVIDED HEREIN AND THE REMEDY FOR VIOLATIONS OF ANY IMPLIED WARRANTY SHALL BE LIMITED TO REPAIR OR REPLACEMENT OF THE DEFECTIVE PRODUCT PURSUANT TO THE TERMS CONTAINED HEREIN. INVACARE SHALL NOT BE LIABLE FOR ANY CONSEQUENTIAL OR INCIDENTAL DAMAGES WHATSOEVER.

THIS WARRANTY SHALL BE EXTENDED TO COMPLY WITH STATE/PROVINCIAL LAWS AND REQUIREMENTS.



Yes, you can.™

Invacare Corporation

www.invacare.com

USA

One Invacare Way
Elyria, Ohio USA
44036-2125
800-333-6900

Canada

5970 Chedworth Way
Mississauga, Ontario
L5R 3T9, Canada
905-890-8838

Invacare and Top End are registered trademarks of Invacare Corporation.

Yes, you can. and Terminator are trademarks of Invacare Corporation.

3-in-1 oil is a registered trademark of American Home Products Corporation.

Teflon is a registered trademark of E.I. Du Pont De Nemours and Company.

© 2001 Invacare Corporation

Part No. 1104910 Rev A (1) 04/01